

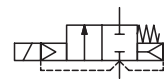

SOLENOID VALVES

pilot operated, built-in pilot
stainless steel body, floating diaphragm
3/8 to 1

NC



NO

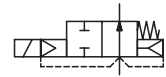

2/2
Series
238

FEATURES

- Minimum operating pressure differential ΔP 0,35 bar
- Two way valves for automatic control of water, air and inert gas and other gases/liquids compatible with the sealing materials used
- Stainless steel body for wide compatibility with environments and fluids
- Interchangeability of magnetic heads, AC and DC
- The solenoid valves satisfy all relevant EU Directives

GENERAL

Differential pressure	See «SPECIFICATIONS» [1 bar = 100 kPa]			
Ambient temperature range	-10°C to +60°C			
Maximum viscosity	37 cSt (mm ² /s)			
Response time	3/8	1/2	3/4	1
opening time (ms)	300	300	300	1500
closing time (ms)	1000	1000	1000	2000

fluids (*)	temperature range (TS)	seal materials (*)
air, inert gas and water	0°C to +130°C	FPM (fluoroelastomer)

MATERIALS IN CONTACT WITH FLUID

(*) Ensure that the compatibility of the fluids in contact with the materials is verified

Body	Stainless steel, AISI 316L
Core tube	Stainless steel
Core and plugnut	Stainless steel
Springs	Stainless steel
Seat	Stainless steel, AISI 316L
Diaphragm & disc valve	FPM
Seals & disc pilot	FPM
Shading coil	Copper

ELECTRICAL CHARACTERISTICS

Coil insulation class	F
Connector	Spade plug (cable Ø 6-8 mm or Ø 6-10 mm)
Connector specification	DIN 43650, 11 mm, industry standard B
for power coil: 4 W/6,9 W	ISO 4400 / EN 175301-803, form A
for power coil: 6,9 W DC	IEC 335
Electrical safety	Moulded IP65 (EN 60529)
Electrical enclosure protection	DC (=) : 24V - 48V
Standard voltages	AC (-) : 24V - 48V - 115V - 230V / 50 Hz
(Other voltages and 60 Hz on request)	

prefix option	power ratings				operator ambient temperature range f (TS) (C°)	replacement coil		type ⁽¹⁾
	inrush ~	holding ~	hot/cold =	~		=		
	(VA)	(VA)	(W)					
SC	12 -	6 -	4 -	4 / 6,9 4 / 5	-10 to +60 -10 to +60	230 V/50 Hz -	400127-142 400727-185	01 ⁽²⁾ 02

⁽¹⁾ Refer to the dimensional drawings on the following page.

⁽²⁾ UL/CSA certified.

SPECIFICATIONS

pipe size	orifice size	flow coefficient Kv		operating pressure differential (bar)			power coil (W)		catalogue number	options		
				min.	max. (PS)		~	=		maintained man. operator	EPDM	
					air / water (*)							
G	(mm)	(m ³ /h)	(l/min)		~	=			~/=			
NC - Normally closed												
3/8	13,5	2,5	41,7	0,35	12	12	4	6,9	SCG238D101V	MO	E	-
1/2	13,5	3,8	63,3	0,35	12	12	4	6,9	SCG238D102V	MO	E	-
3/4	18	5	83,3	0,35	10	10	4	6,9	SCG238D103V	MO	E	-
1	24	12	200	0,35	10	10	4	6,9	SCG238D104V	MO	E	-
NO - Normally open												
3/8	13,5	2,5	41,7	0,35	12	12	4	5 ⁽²⁾	SCG238D105V	-	E	-
1/2	13,5	3,8	63,3	0,35	12	12	4	5 ⁽²⁾	SCG238D106V	-	E	-
3/4	18	5	83,3	0,35	10	10	4	5 ⁽²⁾	SCG238D107V	-	E	-
1	24	12	200	0,35	10	10	4	5 ⁽²⁾	SCG238D108V	-	E	-

⁽²⁾ Type 02.

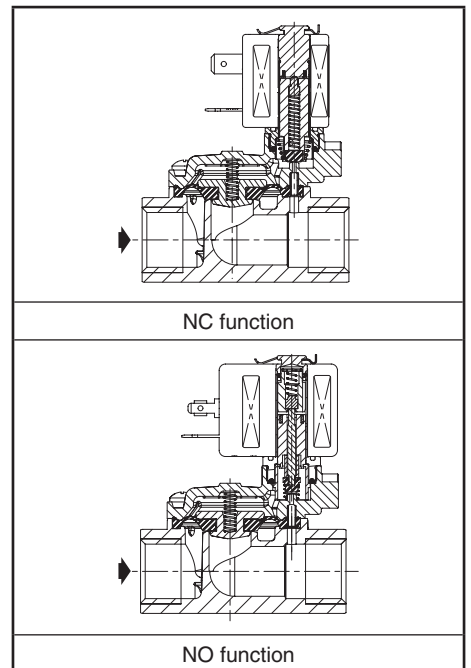

01017GB-2016/R01 Availability, design and specifications are subject to change without notice. All rights reserved.



青岛秉诚自动化设备有限公司
地址：中国·青岛市重庆南路99号海尔云街甲3号楼7F

服务热线：4006-918-365
网址：http://www.asco.store

传真：(86-532)585-10-365
Email：sales@bechinas.com

All leaflets are available on: www.asco.com

V317-1

OPTIONS

- Valves can also be supplied with EPDM (ethylene-propylene) seals, diaphragm and disc. Use the appropriate optional suffix letter for identification
- Explosionproof enclosures for use in zones 1/21-2/22, categories 2-3 to ATEX Directive 2014/34/EU (see "Explosionproof solenoids" section)
- Oxygen service, suffix NV, example: SCG238D102NV
- Plug with visual indication and peak voltage suppression or with cable length of 2 m (see Solenoids, Coils & Accessories section)

INSTALLATION

- The solenoid valves can be mounted in any position without affecting operation
- Threaded pipe connection is standard: G = G (ISO 228/1)
- Installation/maintenance instructions are included with each valve

SPARE PARTS KIT

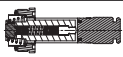
catalogue number	spare parts kit no. ⁽¹⁾	
	 ⁽¹⁾	 ⁽¹⁾
	~/=	~/=
SCG238D101V/102V	C131038V	C140267V
SCG238D103V	C131039V	C140267V
SCG238D104V	C131040V	C140267V
SCG238D105V/106V	C131041V	C140508V
SCG238D107V	C131042V	C140508V
SCG238D108V	C131043V	C140508V

⁽¹⁾ For EPDM version, replace "V" with "E".

ORDERING EXAMPLES:

SC	G	238	D	101	V	230V / 50 Hz
SC	G	238	D	104	E	24V / DC
SC	G	238	D	102	VMO	230V / 50 Hz

prefix — pipe thread — basic number — voltage — suffix

ORDERING EXAMPLES KITS:

C140267	V
C131038	E

basic number — suffix

DIMENSIONS (mm), WEIGHT (kg)



TYPE 01
Prefix "SC" Solenoid
Epoxy moulded
IEC 335 / DIN 43650
IP65

SCG238D101/102/103/104

AC (-): SCG238D105/106/107/108



TYPE 02
Prefix "SC" Solenoid
Epoxy moulded
IEC 335 / ISO 4400
IP65

DC (-): SCG238D105/106/107/108

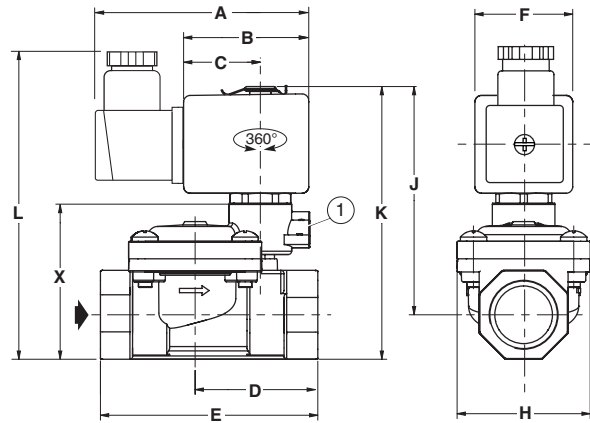
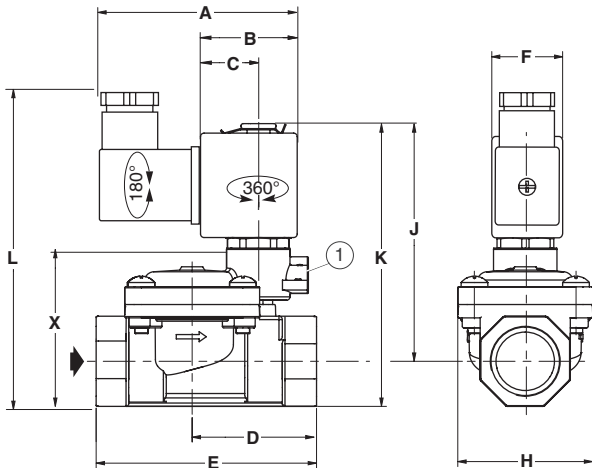

¹ Manual operator location.

type	prefix option	catalogue number	A	B	C	D	E	F	H	J	K	L	X	weight ⁽²⁾	
														NC	NO
01	SC	SCG238D101 / SCG238D105 (-)	60,5	27,5	17	34,5	60	22	40	67	78	95	42	0,33	0,35
		SCG238D102 / SCG238D106 (-)	60,5	27,5	17	37	66	22	40	69	83	100	47	0,45	0,41
		SCG238D103 / SCG238D107 (-)	60,5	27,5	17	43,5	79	22	50	73,5	90	107	54	0,52	0,55
		SCG238D104 / SCG238D108 (-)	60,5	27,5	17	59	105	22	71	85	106	123	70	1,08	1,11
02	SC	SCG238D105 (=)	76	38	23	34,5	60	30	40	67	78	95	42	-	0,35
		SCG238D106 (=)	76	38	23	37	66	30	40	69	83	83	47	-	0,41
		SCG238D107 (=)	76	38	23	43,5	79	30	50	73,5	90	90	54	-	0,55
		SCG238D108 (=)	76	38	23	59	105	30	71	85	106	106	70	-	1,11

⁽²⁾ Incl. coil(s) and connector(s).

All leaflets are available on: www.asco.com

V317-2



青岛秉诚自动化设备有限公司
地址：中国·青岛市重庆南路99号海尔云街甲3号楼7F

服务热线：4006-918-365
网址：<http://www.asco.store>

传真：(86-532)585-10-365
Email：sales@bechinas.com