

AIR PREPARATION

Product index



Products	Pipe connections	Type	Illustration	Series	Page
FR + L air preparation manifold assemblies	1/8 - 1/4	105		342	57
	1/8 to 1/2	651 - 652		651 - 652	40
Particulate Filter Coalescing filter & absorber	1/8 to 3/4	651 - 652		651 - 652	4 - 8
		105		342	59
	1/4 to 3	Delta		901	79
Regulator	mini (water)	1/8 - 1/4		342	71
	- (105/water)	1/8 to 1/2		105 - 651 - 652	12-61-63
	manifold	1/8 to 1/2		651 - 652	16
	pilot operated	1/4 to 1/2/1/4 to 1		652 - R50	13 - 73
	precision	1/4 to 1/2		R80 - R82 - R88	R8x
Particulate filter/regulator	1/8 to 3/4	651 - 652		651-652	19 - 23
Coalescing filter/regulator		105		342	65
Monobloc Filter + Lubricator	1/8 - 1/4	105		342	67
Lubricator	1/8 to 1/2	651 - 652		651 - 652	27
Shut-off isolation valve	1/8 to 1/2	651 - 652		651 - 652	30
Slow-start/quick exhaust valve	1/8 to 1/2	651 - 652		651 - 652	33
Diverter block	1/8 to 1/2	651 - 652		651 - 652	36
Lockout valve	1/2	652		652	38
					77
Accessories		651 - 652		699	48..56
		105		343	69
Pressure switches	-	-		349	(1)

(1) See "COILS AND ACCESSORIES" section.

All leaflets are available on: www.asco.com

Products	pipe connections - internal thread										stainless steel fasteners	flow at 6,3 bar l/min (ANR)	Illustration	Series	Page			
	Modulair 105		651		652			mini (water)										
	1/8	1/4	1/8	1/4	1/4	3/8	1/2	1/8	1/4									
105-651-652																		
FR + L air preparation manifold assemblies															400-450		342	57
															-		651 652	40
Particulate Filter															890-1050		342	59
															885-3700		651 652	4
Coalescing filter & absorber															430-830		651 652	8
Regulator															550-650		342	61
														●	800-7000		651 652	12
Water regulator															-		342	63
Water regulator (mini)															-		342	71
Manifold regulator															640 - 8000		651 652	16
Particulate filter/regulator															550-650		342	65
														●	710-5500		651 652	19
Coalescing filter/regulator															240-540		651 652	23
Monobloc Filter + Lubricator															-		342	67
Lubricator															900-5100		651 652	27
Shut-off isolation valve															1440-8800		651 652	30
Slow-start/quick exhaust valve															780-4650		651 652	33
Diverter block															-		651 652	36
Lockout valve															5910		652	38
Accessories																	699	48..56
Spare parts kits													●	-			343	69

Products	pipe connections - internal thread			Illustration	Series	Page
	105 / 651 / 652					
	1/8	to	1			
105-651-652						
Delivered assembled systems	1/8 to 3/4				Consult our Dynamic Product Modeling Tool on: www.asco.com	

Products	pipe connections - internal thread ØG - pad mount												pad mount	flow at 6,3 bar l/min (ANR)	Illustration	Series	Page
	1/8	1/4	3/8	1/2	3/4	1	1 1/4	1 1/2	2	2 1/2	3						
Pressure switches																	
Adjustable pressure switch with or without protection and status indicators														-		349	(1)
Electronic pressure switch														-		349	(1)
Other air preparation equipment products																	
Miniature regulator														500-650		342	71
Drip leg autodrain														-		342	72
Pilot operated regulator														1850-41700		R50	73
Precision regulator														460		R80 R82	75
														1700		R88	
Lockout valve																VL VT	77
DELTA FILTER																	
Filter														840-52560		Delta	79

(1) See "COILS AND ACCESSORIES" section.

00259GB-2017/R01 Availability, design and specifications are subject to change without notice. All rights reserved.

Table of Contents

651/652 Series

Product Overview	2
Particulate Filter	4
Coalescing Filter	8
Adsorber - Activated Carbon	8
Regulator	12
Manifold Regulator	16
Particulate Filter/Regulator	19
Coalescing Filter/Regulator	23
Lubricator	27
Shut-Off Isolation Valve	30
Slow Start-Quick Exhaust Valve	33
Diverter Block	36
Lockout Valve	38
Air Preparation FR + L Manifold Assemblies	40
Mounting Bracket Dimensional Drawings	42
Bowl and Drain Features	43
280 Series Digital Pressure Switch	44
PS180 Series Pressure Switch	45
Digital Pressure Gauge	45
349 Series Pressure Switch	46
Electric Differential Pressure Indicator (DPI)	47
Electronic Liquid Level Indicator	47
Kits and Service Parts	48

Series 651/652 - Product Overview

651/652 Series Air Preparation Manifold Assembly & Optional Features

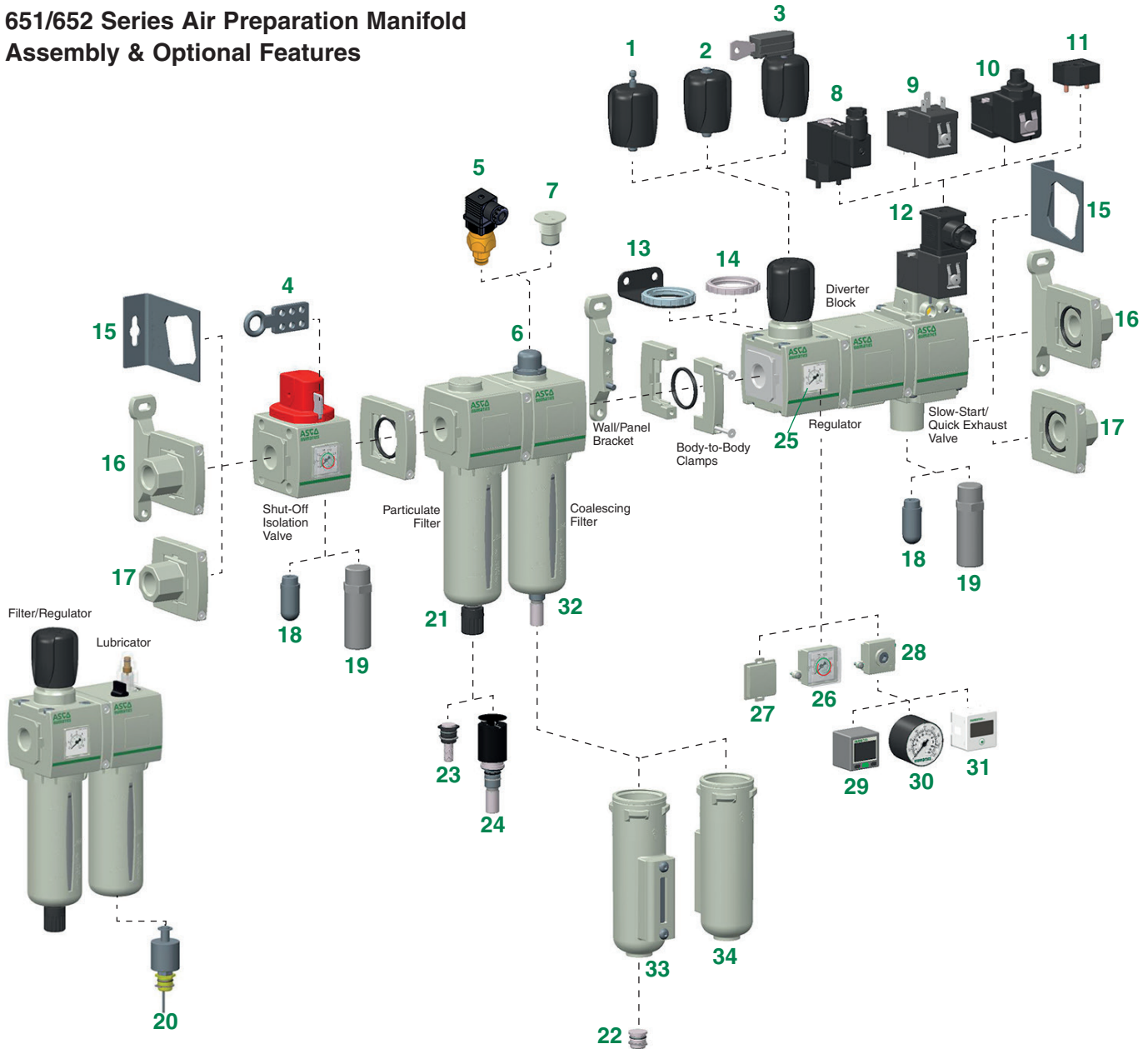

- | | | |
|--|---|--|
| 1) Provision for Key Lockable (Regulator & F/R*) | 15) Side Mounting Brackets | 30) Round Gauge |
| 2) Tamper Resistant (Regulator & F/R*) | 16) End Plates, Body-to-Body Clamps & Wall/ Panel Brackets | 31) Digital Gauge |
| 3) Key Lockable (Regulator & F/R*) | 17) End Plates & Body-to-Body Clamps | 32) Polycarbonate Bowl & Guard |
| 4) Scissor Lock | 18) Polyethylene Muffler | 33) Metal Bowl with Borosilicate (Glass) Sight Gauge |
| 5) Electric Differential Pressure Indicator (Coalescing Filter) | 19) Metal Muffler | 34) Metal Bowl without Sight Gauge |
| 6) Differential Pressure Visual Pop-Up Indicator (Coalescing Filter) | 20) Electronic Liquid Level Indicator | |
| 7) No Differential Pressure Indicator | 21) Semi-Automatic/Manual Drain | |
| 8) 189 Series Vertical Solenoid | 22) Plug for No Drain | |
| 9) 190 Series Horizontal Solenoid | 23) Manual Drain – Stainless Steel | |
| 10) 190 Series Horizontal Solenoid with 4Pin M12 Connection | 24) Automatic Drain – Normally Open – Brass | |
| 11) Pilot Air Operated | 25) Low profile integrated gauge | |
| 12) Horizontal Solenoid | 26) Low profile integrated gauge with Pressure Range Indicators | |
| 13) Panel Nut/Panel Bracket (Regulator & F/R*) | 27) No Gauge Port | |
| 14) Panel Nut (Regulator & F/R) | 28) Port Plate | |
| | 29) Digital Pressure Switch – DPS 280 Series | |

*F/R = Filter/Regulator

All leaflets are available on: www.asco.com

651/652 Series Modular Assembly Mounting Features

Body-to-Body Assembly Clamp

Easy to assemble Body-to-Body clamp, with captive screws. Products are easily assembled in seconds.



End Plates with Body-to-Body Assembly Clamp

The "End Plate" feature allows the user to easily remove the 651/652 series air prep assembly without having to remove the piping. Simply loosen the screws on the Body-to-Body assembly clamps, and the manifold is easily removed in seconds. The kit includes Inlet/Outlet plates, Body-to-Body clamps and o-rings.

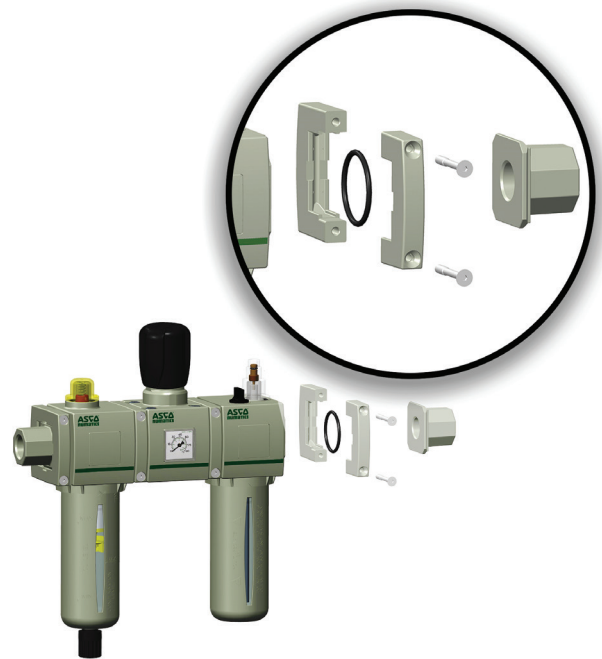

Wall/Panel Bracket

The Wall/Panel Bracket feature is the primary mounting feature for the 651/652 series air prep assemblies. These brackets easily attach to the back of the Body-to-Body assembly clamps using two screws. In addition, this bracket can be used as a support bracket in between any station on the manifold.



Side Mounting Brackets

Side mounting brackets are a quick, effective solution for single elements or light assemblies of few components. (except Lockout Valve)



- Large selection of filtering capacities to remove particulate and water droplets from compressed air or inert gas
- Sintered polyethylene elements include 5 and 25 Microns
- Optional extended temperature range of -40°C to +80°C
- Innovative two position plastic drain with manual and semi-automatic functions. Additional drains include an automatic style (brass) and manual (stainless steel)
- Polycarbonate and Aluminium bowls with or without glass gauge, to meet industry all application requirements
- Threaded ports allow for individual or modular mounting
- Air Purity Class according to ISO 8573-1: 2010



Performance Data				
Series	651		652	
Port sizes	1/8, 1/4		1/4, 3/8, 1/2	
Thread type	G (NPTF in option)			
Nominal flow - ISO 6358 P1 = 6,3 bar ΔP = 1 bar	1/8	Micron Rating	l/min (ANR)	l/min (ANR)
		5 μm	885	-
	25 μm	920	-	
	1/4	5 μm	1250	2020
		25 μm	1410	2250
	3/8	5 μm	-	2190
		25 μm	-	3390
	1/2	5 μm	-	2290
		25 μm	-	3700
	Maximum inlet pressure (bar)	Polycarbonate bowl	16	
Aluminium bowl		16		
Ambient temperature range (°C)	-20 to +50			
Fluid temperature range (°C)	-20 to +50			
Fluid	air or inert gas			
Weight (kg)	w/Polycarbonate bowl	0,238	0,426	
	w/Aluminium bowl	0,382	0,553	

Materials in contact with fluid	
Body	Aluminium
Body covers	Polyamide
Seals	NBR
Filter element	Sintered polyethylene
Bowl	Polycarbonate or aluminium

Air Purity Class - ISO 8573-1: 2010	
5 μm	(5:8:4)
25 μm	(6:8:4)

HOW TO ORDER

Particulate Filter

G 651 A B B P 2 J A00 0 N

[Configurator - CAD Files](#)

Thread connection

- G = ISO 228/1-G*
- 8 = NPTF

Product series

- 651
- 652

Revision letter

- A

Product type

- B = Filter - Particulate

Elements

- B = 5 µm (White)
- J = 25 µm (Yellow)

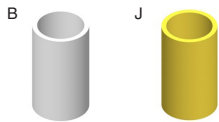

Bowl type

- K = Metal bowl without sight gauge
- L = Metal bowl with sight gauge (glass)
- P = Polycarbonate bowl with bowl guard



Drain type

- 0 = Without
- A = Auto drain normally open
- N = Manual/Semi-automatic drain
- Q = Manual drain - Stainless steel



Options***

- A00 = Without
- 101 = Side Mounting Brackets
- 105 = High temperature (+80°C)
- 106 = Low temperature (-40°C)**
- 109 = FPM seals
- 117 = ATEX zones 1-21 ⚠
- 202 = 105 + 109
- 2A9 = 105 + 106

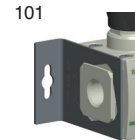

Port size

- 1 = 1/8 (651 Series)
- 2 = 1/4 (651 or 652 Series)
- 3 = 3/8 (652 Series)
- 4 = 1/2 (652 Series)

* Conforms to ISO standards 1179-1

** Compressed air must be dry enough so no ice formation is present on the product. All bowls should be emptied prior to ambient temperatures dropping below 0°C.

*** [If multiple options are required, please use the on-line CAD configurator on the website to generate the part number \(www.asco.com\).](#)

01801GB-2016/R01
Availability, design and specifications are subject to change without notice. All rights reserved.

All leaflets are available on: www.asco.com

Dimensions: mm
Dimensional Drawing - 651/652 Series Particulate Filter Configurator - CAD Files

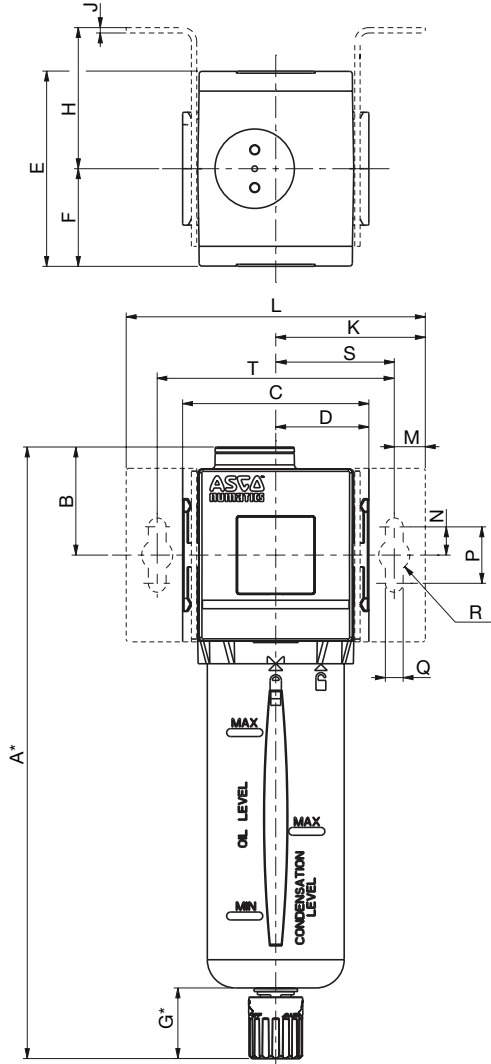

Cross Section - 651/652 Series Particulate Filter

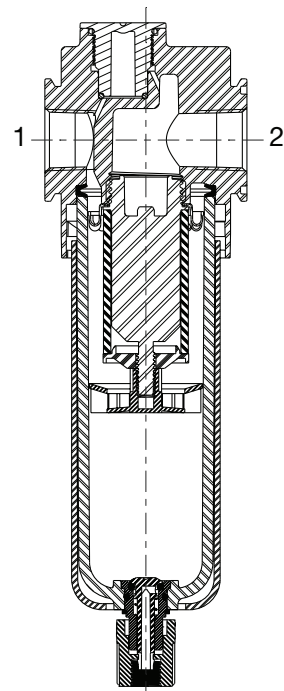

To remove bowl allow:
651 - 44 mm
652 - 75 mm
from the bottom
of the bowl drain.

Series	A	B	C	D	E	F	G	H	J
651	197	33,8	50	25	58	29	25	44,5	1,27
652	217	38,3	66	33	69	34,5	25	50	1,9

Series	K	L	M	N	P	Q	ØR	S	T
651	46	92	11	10	20	6,3	11	35	70
652	53	106	11	10	20	6,3	11	42	84

* Variable dimension based on type of drain that is specified. If an Automatic Drain is specified, add another 5 mm to "G " dimension, which also adds 5 mm to the "A" dimension.

Particulate Filter Flow Charts

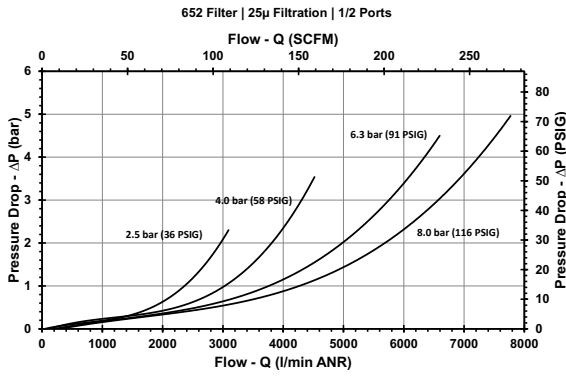
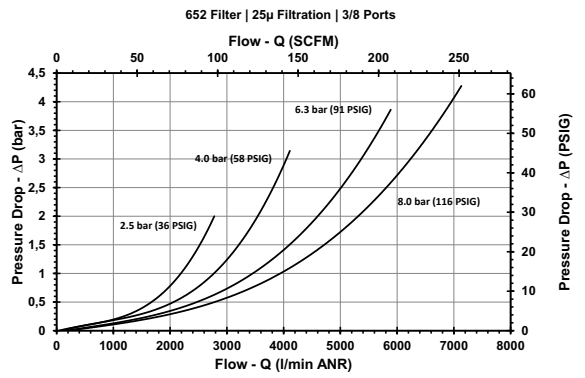
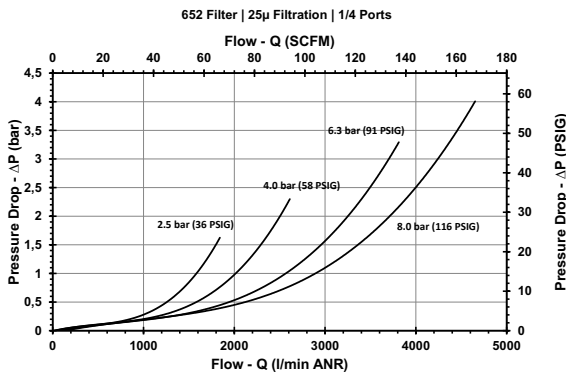
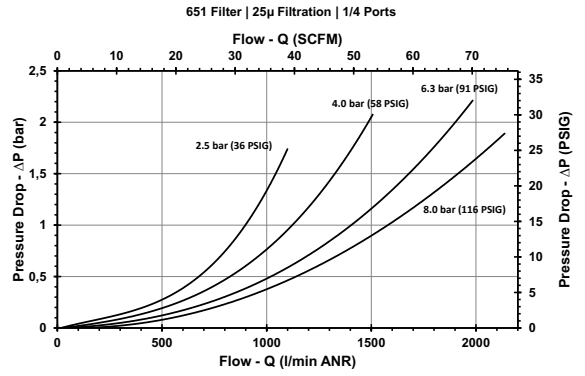
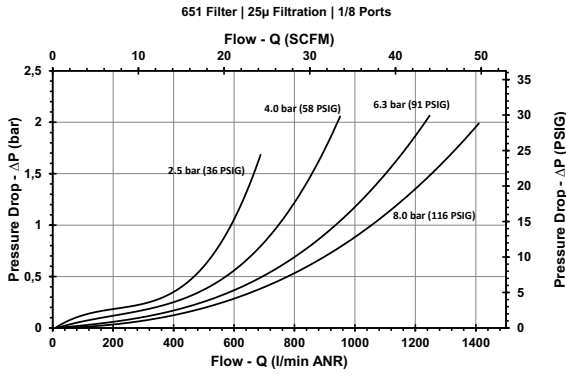

01801GB-2016/R01
Availability, design and specifications are subject to change without notice. All rights reserved.

All leaflets are available on: www.asco.com

COALESCING FILTER & ADSORBER

- Extensive range of coalescing filter elements to remove oil and sub-micron particles down to 0,01 microns
- Optional 3 micron pre-filter integrated in the coalescing element eliminates the need for a separate particulate element. Coalescing filter elements include 0,3 and 0,01 microns
- Adsorber filter (activated carbon) for removal of odors and hydrocarbon vapor
- Innovative two position plastic drain with manual and semi-automatic functions. Additional drains include an automatic style (brass) and manual (stainless steel).
- Polycarbonate and Aluminium bowls with or without glass gauge, to meet industry all a pplication requirements
- Visual or electrical differential pressure Indicators for condition monitoring of filter element
- Air Purity Class according to ISO 8573-1: 2010
- Optional extended temperature range of +80°C

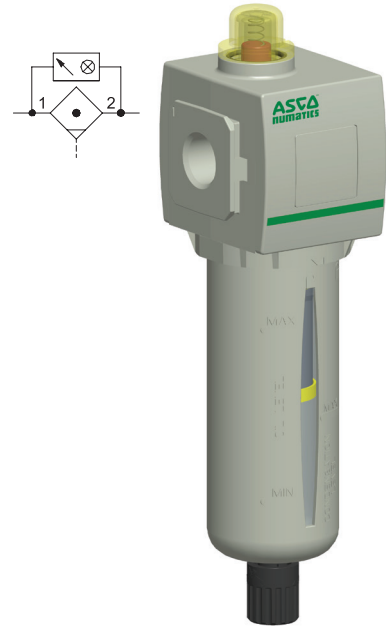

Performance Data				
Series		651		652
Port sizes		1/8, 1/4		1/4, 3/8, 1/2
Thread type		G (NPTF in option)		
		Micron Rating	l/min (ANR)	l/min (ANR)
Nominal flow - ISO 6358 P1 = 6,3 bar ΔP = 0,35 bar	1/8	0,3 μm	430	-
		0,01 μm	310	-
	1/4	0,3 μm	480	800
		0,01 μm	350	710
	3/8	0,3 μm	-	820
		0,01 μm	-	790
	1/2	0,3 μm	-	870
		0,01 μm	-	830
Maximum inlet pressure (bar)		Polycarbonate	16	
		Aluminium	16	
Ambient temperature range (°C)		+1,7 to +50		
Fluid temperature range (°C)		+1,7 to +50		
Fluid		air or inert gas		
Weight (kg)		w/Polycarbonate bowl	0,245	0,442
		w/Aluminium bowl	0,390	0,569

Materials in contact with fluid	
Body	Aluminium
Body covers	Polyamide
Seals	NBR
Coalescing filter element	Borosilicate Microfiber & Polyester
Filter element end cap	Polypropylene
Adsorber	Activated carbon
Bowl	Polycarbonate or aluminium

Air Purity Class - ISO 8573-1: 2010*	
0,3 μm	(3:7:3)
0,01 μm	(2:7:2)

* 651 Series maximum flow at 6,3 bar inlet pressure to maintain air purity class is 100 l/min.

* 652 Series maximum flow at 6,3 bar inlet pressure to maintain air purity class is 300 l/min.

HOW TO ORDER

Coalescing Filter

G 651 A F D P 2 H A00 0 N

[Configurator - CAD Files](#)

Thread connection

- G = ISO 228/1-G*
- 8 = NPTF

Product series

- 651
- 652

Revision letter

- A

Product type

- A = Adsorber - Activated Carbon
- F = Filter - Coalescing

Elements

- D = 0,3 micron - Coalescer (Green)
- E = 0,01 micron - Coalescer (Red)
- F = Adsorber - Activated carbon (Grey)
- M = 0,3 micron coalescer with 3 micron prefilter (Green)
- N = 0,01 micron coalescer with 3 micron prefilter (Red)

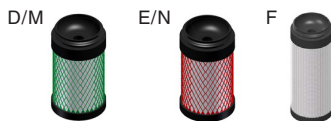

Bowl type

- K = Metal bowl without sight gauge
- L = Metal bowl with sight gauge (glass)
- P = Polycarbonate bowl with bowl guard



Drain type

- 0 = Without
- A = Auto drain normally open
- N = Manual/Semi-automatic drain
- Q = Manual drain - Stainless steel



Options**

- A00 = Without
- 101 = Side Mounting Brackets
- 105 = High temperature (+80°C)
- 109 = FPM seals
- 117 = ATEX zones 1-21
- 202 = 105 + 109

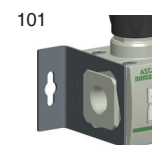

Indication type

- E = Electrical differential pressure indicator
- H = Differential pressure visual pop-up indicator
- J = No differential pressure indicator

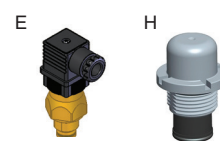

Port size

- 1 = 1/8 (651 Series)
- 2 = 1/4 (651 or 652 Series)
- 3 = 3/8 (652 Series)
- 4 = 1/2 (652 Series)

* Conforms to ISO standards 1179-1.

** If multiple options are required, please use the on-line CAD configurator on the website to generate the part number (www.asco.com).

Dimensions: mm

Dimensional Drawing - 651/652 Series Coalescing Filter and Adsorber Filter

[Configurator - CAD Files](#)

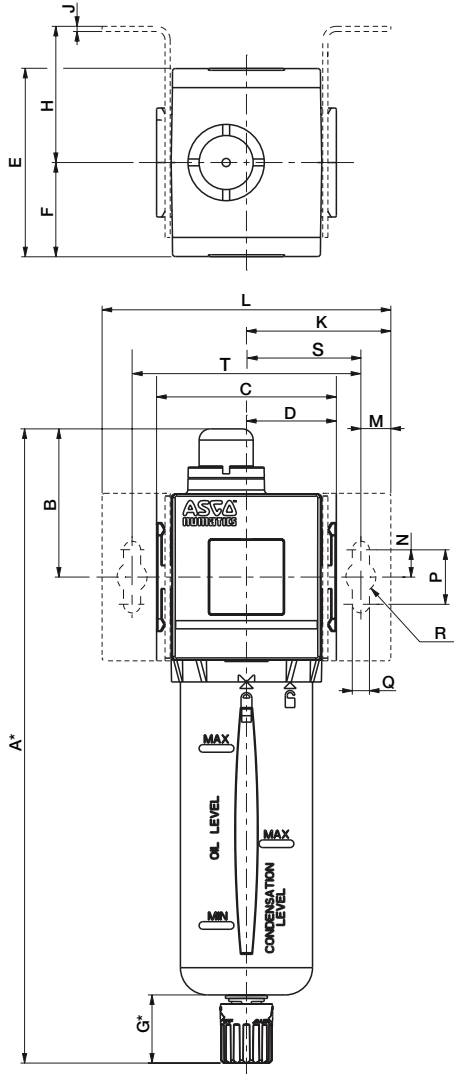

Cross Section - 651/652 Series Coalescing Filter

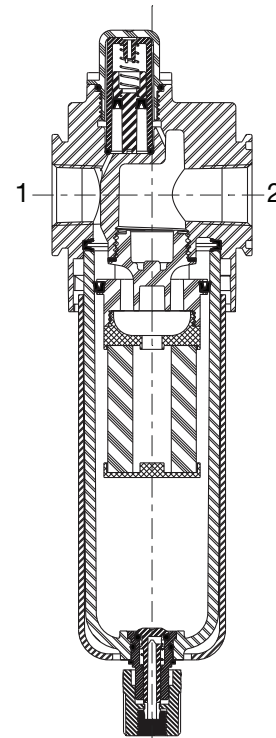

To remove bowl allow:
651 - 60 mm
652 - 80 mm
from the bottom
of the bowl drain.

Series	A	B	C	D	E	F	G	H	J
651	213	50	50	25	58	29	25	44,5	1,27
652	233	54,4	66	33	69	34,5	25	50	1,9

Series	K	L	M	N	P	Q	R	S	T
651	46	92	11	10	20	6,3	11	35	70
652	53	106	11	10	20	6,3	11	42	84

* Variable dimension based on type of drain that is specified. If an Automatic Drain is specified, add another 5 mm to "G" dimension, which also adds 5 mm to the "A" dimension.

Coalescing Filter Flow Charts

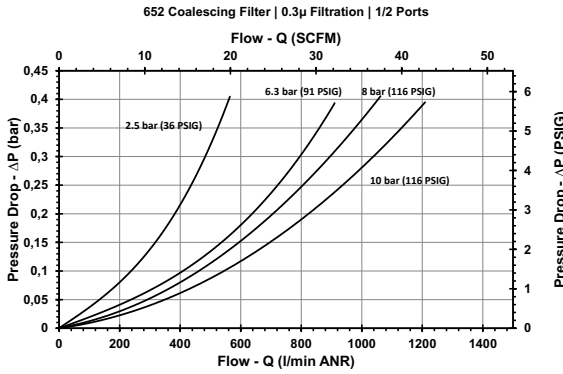
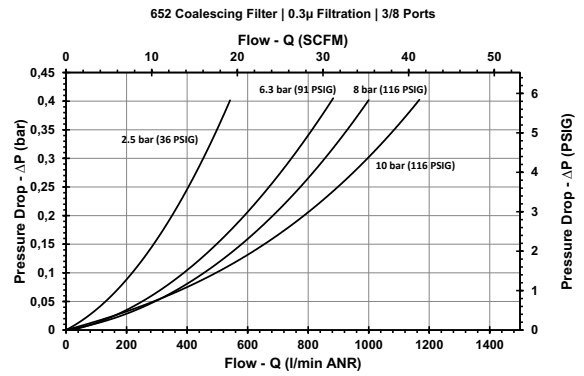
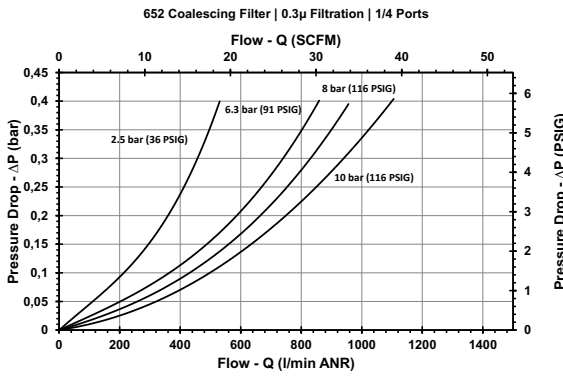
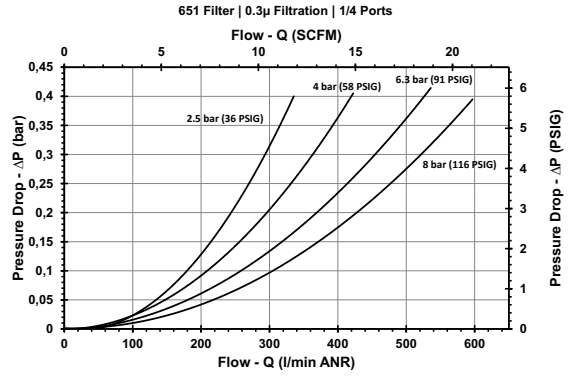
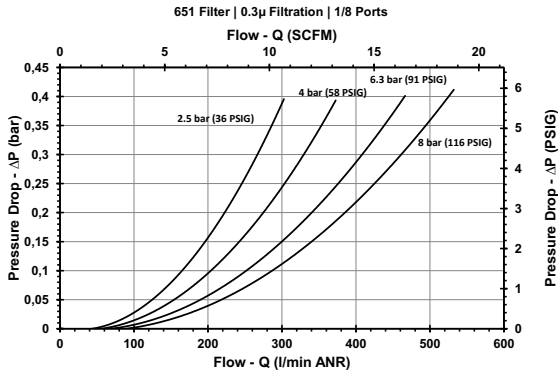

01802GB-2016/R01
Availability, design and specifications are subject to change without notice. All rights reserved.

All leaflets are available on: www.asco.com

- High flow with a wide range of adjustable output pressure ranges
- Flows in excess of 7000 l/min
- Maintains constant downstream pressure even during fluctuations in upstream pressure
- Optional extended temperature range of -40°C to +80°C
- Optional low profile integrated gauge, round gauge, digital gauge or digital pressure switch
- Key lockable and tamper resistant options
- Threaded ports allow for individual or modular mounting

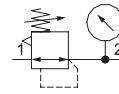

Performance Data			
Series		651	652
Port sizes		1/8, 1/4	1/4, 3/8, 1/2
Thread type		G (NPTF in option)	
		l/min (ANR)	
Nominal flow - ISO 6358 P1 = 10 bar Setpoint P2 = 6,3 bar ΔP = 1 bar	1/8	800	-
	1/4	2060	4120
	3/8	-	6530
	1/2	-	7000
Maximum inlet pressure (bar) P1		16	
Adjustable pressure ranges (bar) P2		0,2 to 3	
		0,5 to 10	
Hysteresis (bar)		0,3	0,2
Ambient temperature range (°C)		-20 to +50	
Fluid temperature range (°C)		-20 to +50	
Fluid		air or inert gas	
Weight (kg)		0,215	0,431

Materials in contact with fluid	
Body	Aluminium
Body covers	Polyamide
Seals	NBR
Springs	Stainless steel

HOW TO ORDER

Regulator

G 651 A R 0 0 2 G A00 H 0

[Configurator - CAD Files](#)

Thread connection
G = ISO 228/1-G*
8 = NPTF

Product series
651
652

Revision letter
A

Product type
K = Regulator "Quick Relief Option"
R = Regulator**
W = Pilot Operated Regulator



Port size
1 = 1/8 (651 Series)
2 = 1/4 (651 or 652 Series)
3 = 3/8 (652 Series)
4 = 1/2 (652 Series)

Gauge type
B = Digital pressure switch - PNP
C = Digital pressure switch - NPN
D = Digital gauge
G = Low profile integrated gauge bar/PSI
J = Low profile integrated gauge bar/PSI with pressure range indicators
Q = Round gauge bar/PSI
0 = No gauge port
P = Port Plate Rc 1/8

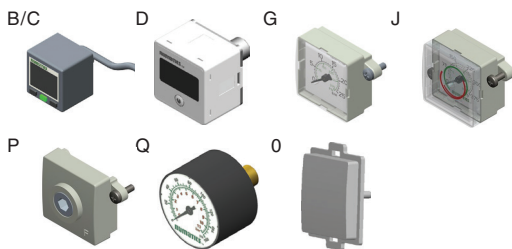

Pressure range
D = 0,2..3 bar
H = 0,5..10 bar

Options****
A00 = Without option
101 = Side Mounting Brackets
102 = Panel Nut
103 = Tamper resistant
104 = Key lockable
105 = High temperature (+80°C)
106 = Low temperature (-40°C)**
109 = FPM seals
113 = Stainless steel fasteners
114 = Provision for key lock
117 = ATEX zones 1-21
119 = Panel Bracket with Panel Nut
121 = Non-relieving
122 = Bottom oriented pressure adjustment
123 = Gauge type mounted for right-to-left flow
202 = 105 + 109
2A9 = 105 + 106

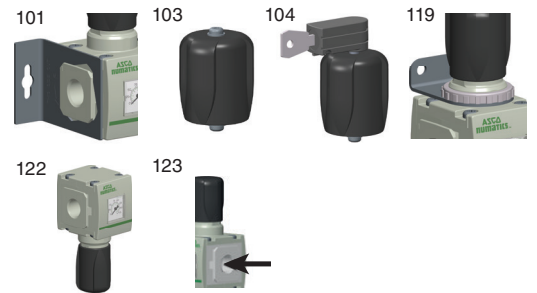

01803GB-2016/R01
Availability, design and specifications are subject to change without notice. All rights reserved.

* Conforms to ISO standards 1179-1.
** Relieving standard; use option 121 for non-relieving
*** Compressed air must be dry enough so no ice formation is present on the product.
**** [If multiple options are required, please use the on-line CAD configurator on the website to generate the part number \(www.asco.com\).](#)

All leaflets are available on: www.asco.com

Dimensions: mm

Dimensional Drawing - 651/652 Series Regulator

[Configurator - CAD Files](#)

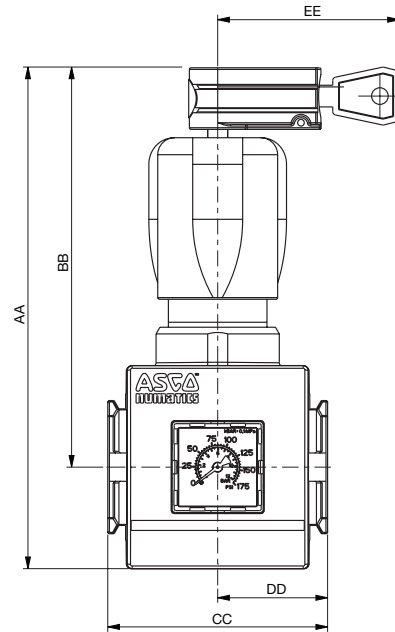
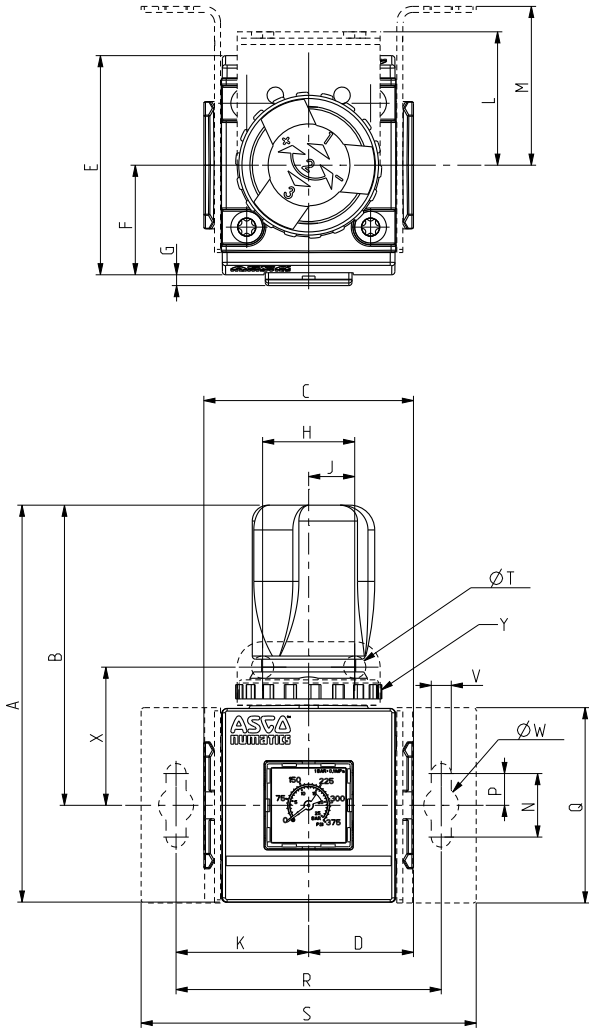

Series	AA	BB	CC	DD	EE
651	121,5	96	50	25	54,6
652	151	120	66	33	55

Series	A	B	C	D	E	F	G	H	J	K	L
651	103	77,5	50	25	58	29	3,4	29	14,5	35	42
652	125	94,5	66	33	69	34,5	2,5	29	14,5	41,75	42

Series	M	N	P	Q	R	S	ØT	V	ØW	X	Y
651	44,5	20	10	50	70	92	7	6,3	11	39,1	M30 x 2
652	50	20	10	61,5	83,5	105,5	7	6,3	11	43,5	M37 x 2

Cross Section - 651/652 Series Regulator

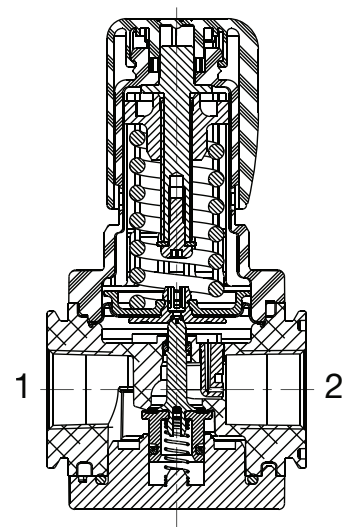

Regulator Flow Charts

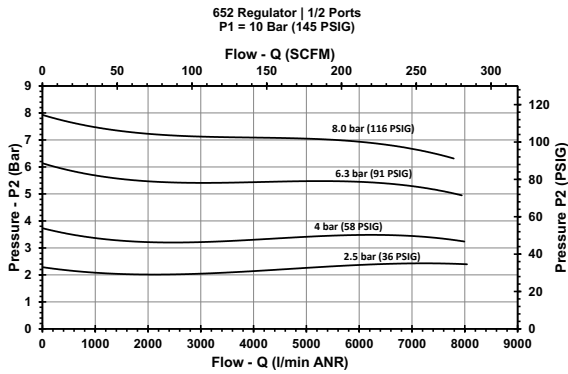
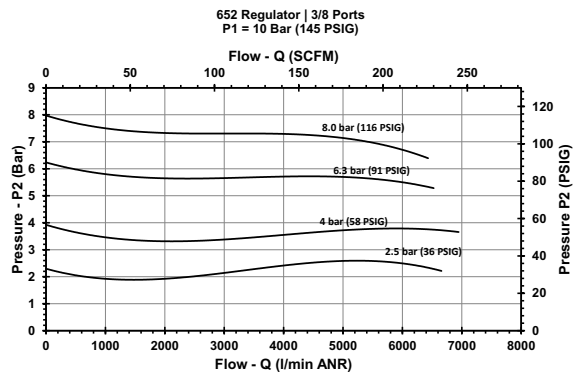
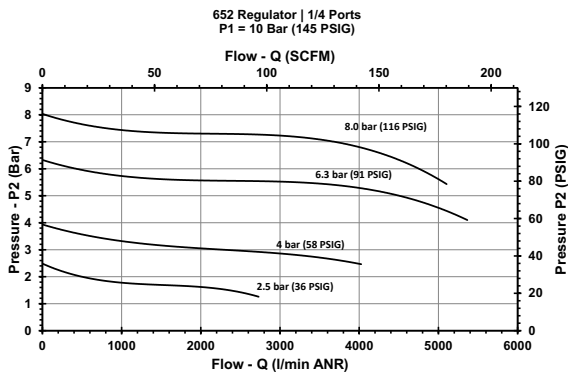
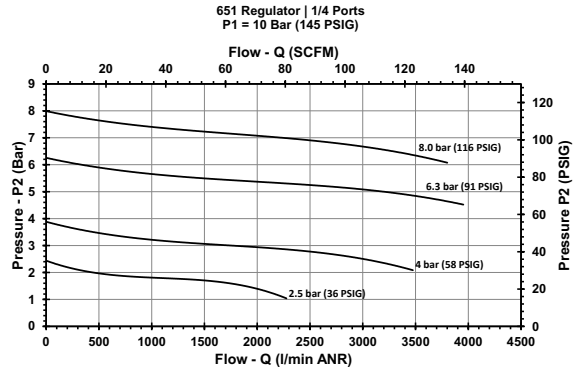
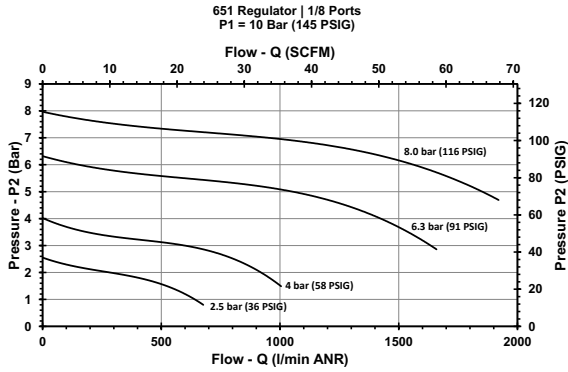

01803GB-2016/R01
Availability, design and specifications are subject to change without notice. All rights reserved.

All leaflets are available on: www.asco.com

- High flow with a wide range of adjustable output pressure ranges
- Flows in excess of 8000 l/min
- Allows for a common inlet supply pressure within the regulator manifold, while maintaining several adjustable output pressures
- Optional low profile integrated gauge, round gauge, digital gauge or digital pressure switch
- Optional extended temperature range of -40°C to +80°C
- Key lockable and tamperproof options

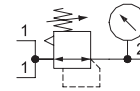

Performance Data			
		651	652
Port sizes	P1 (Inlet)	1/4	1/2
	P2 (Outlet)	1/8	3/8
Thread type		G (NPTF in option)	
Nominal flow - ISO 6358		l/min (ANR)	
P1 = 10 bar Setpoint P2 = 6,3 bar $\Delta P = 1$ bar		840	8000
Maximum inlet pressure (bar) P1		16	
Adjustable pressure ranges (bar) P2		0,2 to 3	
		0,5 to 10	
Hysteresis (bar)		0,3	0,5
Ambient temperature range (°C)		-20 to +50	
Fluid temperature range (°C)		-20 to +50	
Fluid		air or inert gas	
Weight (kg)		0,215	0,422

Materials in contact with fluid	
Body	Aluminium
Body covers	Polyamide
Seals	NBR
Springs	Stainless steel

HOW TO ORDER

Manifold Regulator

G 651 A M 0 0 2 G A00 H 0

[Configurator - CAD Files](#)

Thread connection

G = ISO 228/1-G*
8 = NPTF

Pressure range

D = 0,2..3 bar
H = 0,5..10 bar

Product series

651
652

Revision letter

A

Product type

M = Manifold Regulator**
M



Port size

2 = 1/4 Inlet (1/8 Outlet) (651 Series)
4 = 1/2 Inlet (3/8 Outlet) (652 Series)

Gauge type

B = Digital pressure switch - PNP
C = Digital pressure switch - NPN
D = Digital gauge
G = Low profile integrated gauge bar/PSI
J = Low profile integrated gauge bar/PSI with pressure range indicators
Q = Round gauge bar/PSI
0 = No gauge port
P = Port Plate Rc 1/8

Options****

A00 = Without option
101 = Side Mounting Brackets
102 = Panel Nut
103 = Tamper resistant
104 = Key lockable
105 = High temperature (+80°C)
106 = Low temperature (-40°C)**
109 = FPM seals
113 = Stainless steel fasteners
114 = Provision for key lock
117 = ATEX zones 1-21 ⚠
119 = Panel Bracket with Panel Nut
121 = Non-relieving
122 = Bottom oriented pressure adjustment
123 = Gauge type mounted for right-to-left flow
202 = 105 + 109
2A9 = 105 + 106

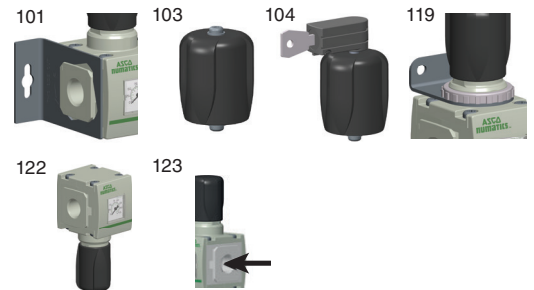
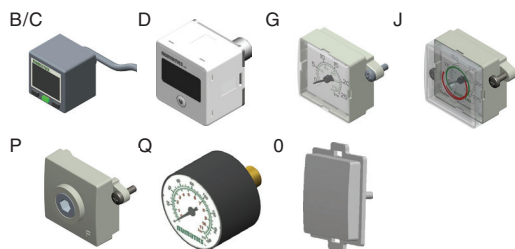

* Conforms to ISO standards 1179-1.

** Relieving standard; use option 121 for non-relieving

*** Compressed air must be dry enough so no ice formation is present on the product.

**** If multiple options are required, please use the on-line CAD configurator on the website to generate the part number (www.asco.com).

Dimensions: mm

Dimensional Drawing - 651/652 Series Manifold Regulator

[Configurator - CAD Files](#)

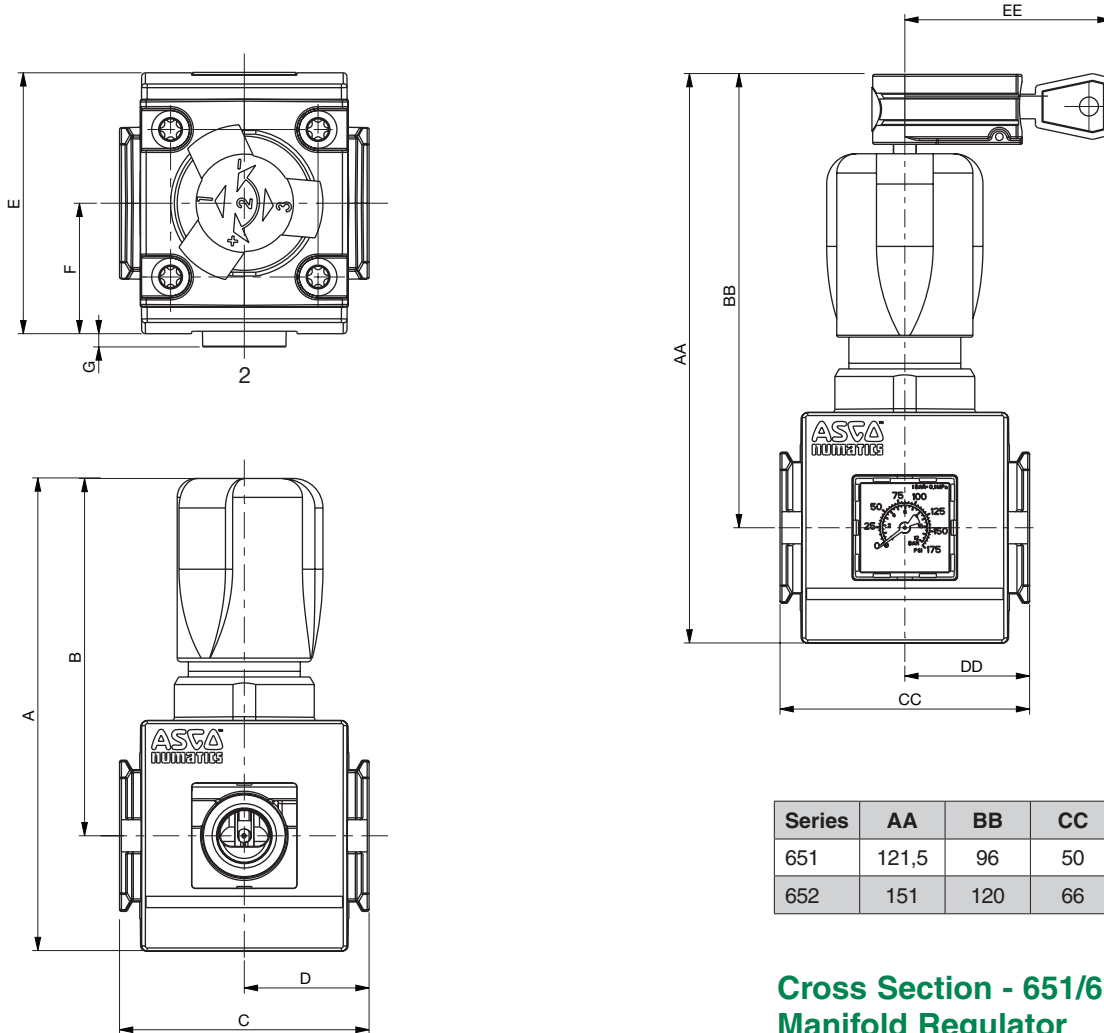

Series	AA	BB	CC	DD	EE
651	121,5	96	50	25	54,6
652	151	120	66	33	55

Series	A	B	C	D	E	F	G
651	103	77,5	50	25	58	29	0,3
652	125	94,5	66	33	69	34,5	3,5

Cross Section - 651/652 Series Manifold Regulator

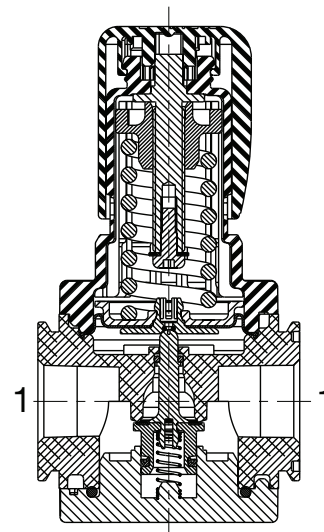

- High flow with a wide range of adjustable output pressure ranges
- Optional low profile integrated gauge, round gauge, digital gauge or digital pressure switch
- Optional extended temperature range of -40°C to +80°C
- Threaded ports allow for individual or modular mounting
- Sintered polyethylene elements include 5 and 25 Microns
- Innovative two position plastic drain with manual and semi-automatic functions. Additional drains include an automatic style (brass) and manual (stainless steel)
- Polycarbonate and Aluminium bowls with or without glass gauge, to meet industry all application requirements
- Key lockable and tamper resistant models
- Air Purity Class according to ISO 8573-1: 2010

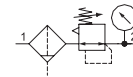

Performance Data					
Series		651		652	
Port sizes		1/8, 1/4		1/4, 3/8, 1/2	
Thread type		G (NPTF in option)			
Nominal flow - ISO 6358 P1 = 10 bar Setpoint P2 = 6,3 bar ΔP = 1 bar	1/8	Micron Rating	l/min (ANR)	l/min (ANR)	
		5 μm	710	-	
	1/4	25 μm	730	-	
		5 μm	2240	3800	
	3/8	25 μm	2360	4120	
		5 μm	-	4450	
	1/2	25 μm	-	5420	
		5 μm	-	4490	
	Maximum inlet pressure (bar)	Polycarbonate bowl		16	
		Aluminium bowl		16	
Adjustable pressure ranges (bar)		0,2 to 3			
		0,5 to 10			
Hysteresis (bar)		0,3	0,5		
Ambient temperature range (°C)		-20 to +50			
Fluid temperature range (°C)		-20 to +50			
Fluid		air or inert gas			
Weight (kg)	w/Polycarbonate bowl		0,304	0,546	
	w/Aluminium bowl		0,449	0,688	

Materials in contact with fluid	
Body	Aluminium
Body covers	Polyamide
Seals	NBR
Springs	Stainless steel
Filter element	Sintered polyethylene
Bowl	Polycarbonate or aluminium

Air Purity Class - ISO 8573-1: 2010	
5 μm	(5:8:4)
25 μm	(6:8:4)

01805GB-2016/R02-
Availability, design and specifications are subject to change without notice. All rights reserved.

All leaflets are available on: www.asco.com

HOW TO ORDER

Particulate Filter/Regulator

G 651 A P B P 2 G A00 H N

[Configurator - CAD Files](#)

Thread connection

- G = ISO 228/1-G*
- 8 = NPTF

Product series

- 651
- 652

Revision letter

- A

Product type

- P = Filter/Regulator - Particulate

Elements

- B = 5 µm (White)
- J = 25 µm (Yellow)

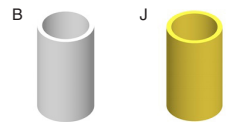

Bowl type

- K = Metal bowl without sight gauge
- L = Metal bowl with sight gauge (glass)
- P = Polycarbonate bowl with bowl guard

Port size

- 1 = 1/8 (651 Series)
- 2 = 1/4 (651 or 652 Series)
- 3 = 3/8 (652 Series)
- 4 = 1/2 (652 Series)

Gauge type

- B = Digital pressure switch - PNP
- C = Digital pressure switch - NPN
- D = Digital gauge
- G = Low profile integrated gauge bar/PSI
- J = Low profile integrated gauge bar/PSI with pressure range indicators
- Q = Round gauge bar/PSI
- 0 = No gauge port
- P = Port Plate Rc 1/8

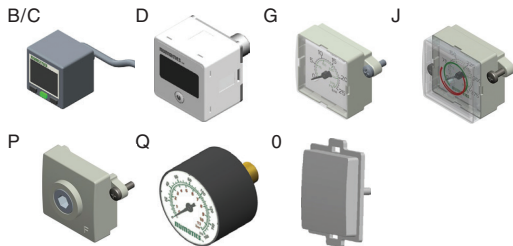

Drain type

- 0 = Without
- A = Auto drain normally open
- N = Manual/Semi-automatic drain
- Q = Manual drain - Stainless steel



Pressure range

- D = 0,2..3 bar
- H = 0,5..10 bar

Options***

- A00 = Without option
- 101 = Side Mounting Brackets
- 102 = Panel Nut
- 103 = Tamper resistant
- 104 = Key lockable
- 105 = High temperature (+80°C)
- 106 = Low temperature (-40°C)**
- 109 = FPM seals
- 113 = Stainless steel fasteners
- 114 = Provision for key lock
- 117 = ATEX zones 1-21
- 119 = Panel Bracket with Panel Nut
- 121 = Non-relieving
- 123 = Gauge type mounted for right-to-left flow
- 202 = 105 + 109
- 2A9 = 105 + 106

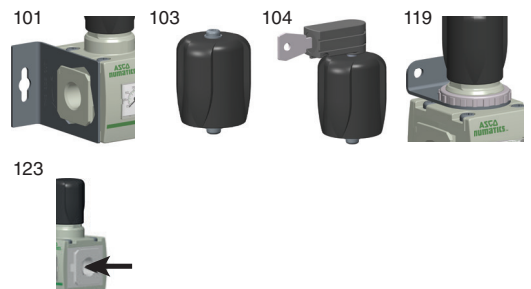

* Conforms to ISO standards 1179-1.

** Compressed air must be dry enough so no ice formation is present on the product. All bowls should be emptied prior to ambient temperatures dropping below 0°C.

*** [If multiple options are required, please use the on-line CAD configurator on the website to generate the part number \(www.asco.com\).](#)

Dimensions: mm

Dimensional Drawing - 651/652 Series Particulate Filter/Regulator

[Configurator - CAD Files](#)

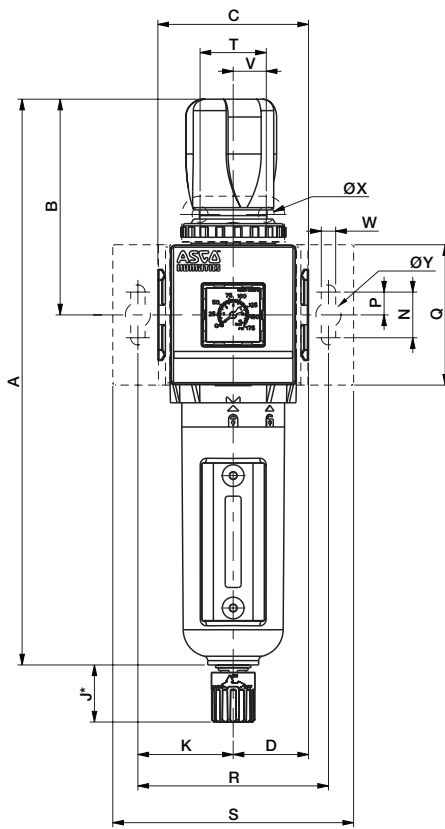
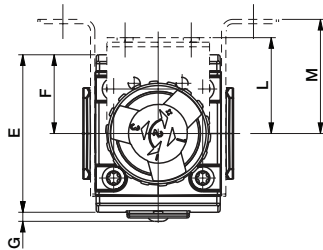

Cross Section - 651/652 Series Particulate Filter/Regulator

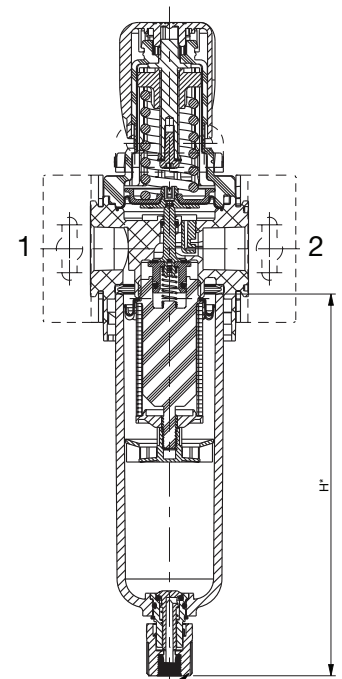

To remove bowl allow:
651 - 44 mm
652 - 75 mm
from the bottom
of the bowl drain.

Series	A	B	C	D	E	F	G	H	J	K	L
651	215,5	77,5	50	25	58	29	3,4	116	25	35	42
652	248	94,5	66	33	69	30,5	4	160	25	41,75	42

Series	M	N	P	Q	R	S	T	V	W	ØX	ØY
651	44,5	20	10	50	70	92	29	14,5	6,3	7	11
652	50	20	10	61,5	84	105,5	29	14,5	6,3	7	11

* Variable dimension based on type of drain that is specified. If an Automatic Drain is specified, add another 5 mm to "J" dimension.

01805GB-2016/R01
Availability, design and specifications are subject to change without notice. All rights reserved.

All leaflets are available on: www.asco.com

Particulate Filter/Regulator Flow Charts

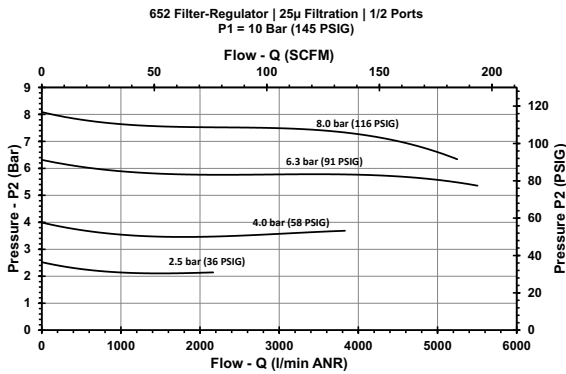
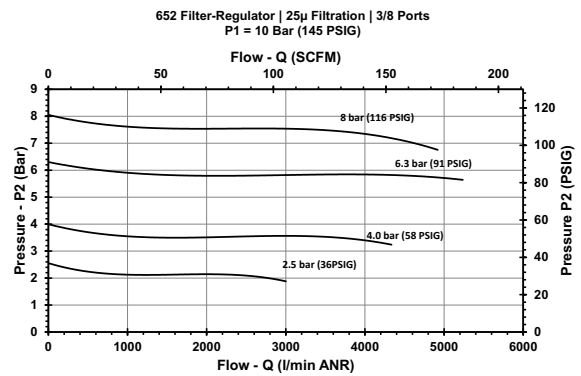
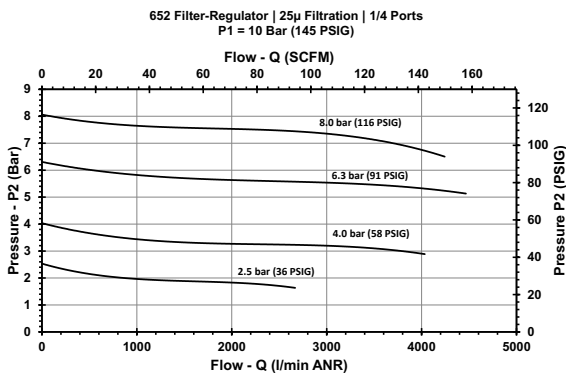
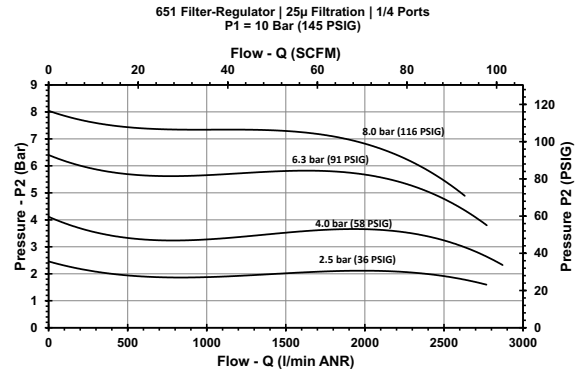
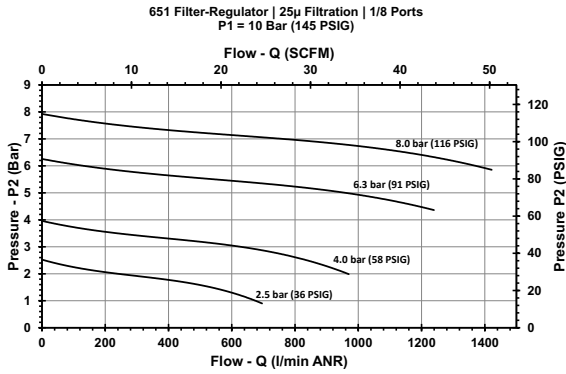

- Extensive range of coalescing filter elements to remove oil and sub-micron particles down to 0,01 microns
- Optional 3 micron pre-filter integrated in the coalescing element eliminates the need for a separate particulate element. Coalescing filter elements include 0,3 and 0,01 microns
- Optional low profile integrated gauge, round gauge, digital gauge or digital pressure switch
- Optional extended temperature range of +80°C
- Threaded ports allow for individual or modular mounting
- Innovative two position plastic drain with manual and semi-automatic functions. Additional drains include an automatic style (brass) and manual (stainless steel)
- Polycarbonate and Aluminium bowls with or without glass gauge, to meet industry all application requirements

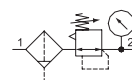

Performance Data				
		651		652
Port sizes		1/8, 1/4		1/4, 3/8, 1/2
Thread type		G (NPTF in option)		
Nominal flow - ISO 6358 P1 = 10 bar Setpoint P2 = 6,3 bar ΔP = 0,35 bar	1/8	Micron Rating	l/min (ANR)	l/min (ANR)
		0,3 μm	240	-
	1/4	0,01 μm	170	-
		0,3 μm	290	320
	3/8	0,01 μm	200	290
		0,3 μm	-	580
	1/2	0,01 μm	-	540
		0,3 μm	-	590
	Maximum inlet pressure (bar) P1	Polycarbonate bowl	16	
		Aluminium bowl	16	
Adjustable pressure ranges (bar)		0,2 to 3		
		0,5 to 10		
Hysteresis (bar)		0,3	0,5	
Ambient temperature range (°C)		+1,7 to +50		
Fluid temperature range (°C)		+1,7 to +50		
Fluid		air or inert gas		
Weight (kg)	w/Polycarbonate bowl	0,308	0,564	
	w/Aluminium bowl	0,453	0,705	

Materials in contact with fluid	
Body	Aluminium
Body covers	Polyamide
Seals	NBR
Springs	Stainless steel
Filter element	Borosilicate Microfiber & Polyester
Filter element end cap	Polypropylene
Bowl	Polycarbonate or aluminium

Air Purity Class - ISO 8573-1: 2010*	
0,3 μm	(3:7:3)
0,01 μm	(2:7:2)

* 651 Series maximum flow at 6,3 bar inlet pressure to maintain air purity class is 100 l/min.

* 652 Series maximum flow at 6,3 bar inlet pressure to maintain air purity class is 300 l/min.

01806GB-2016/R01
Availability, design and specifications are subject to change without notice. All rights reserved.

All leaflets are available on: www.asco.com

HOW TO ORDER

Coalescing Filter/Regulator

G 651 A C D P 2 G A00 H N

[Configurator - CAD Files](#)

Thread connection

G = ISO 228/1-G*
8 = NPTF

Product series

651
652

Revision letter

A

Product type

C = Filter/Regulator - Coalescing

Elements

D = 0,3 micron - Coalescer (Green)
E = 0,01 micron - Coalescer (Red)
M = 0,3 micron coalescer with 3 micron prefilter (Green)
N = 0,01 micron coalescer with 3 micron prefilter (Red)



Bowl type

K = Metal bowl without sight gauge
L = Metal bowl with sight gauge (glass)
P = Polycarbonate bowl with bowl guard

Port size

1 = 1/8 (651 Series)
2 = 1/4 (651 or 652 Series)
3 = 3/8 (652 Series)
4 = 1/2 (652 Series)

Gauge type

B = Digital pressure switch - PNP
C = Digital pressure switch - NPN
D = Digital gauge
G = Low profile integrated gauge bar/PSI
J = Low profile integrated gauge bar/PSI with pressure range indicators
Q = Round gauge bar/PSI
0 = No gauge port
P = Port Plate Rc 1/8

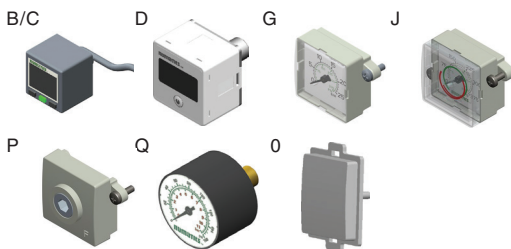

Drain type

0 = Without
A = Auto drain normally open
N = Manual/Semi-automatic drain
Q = Manual drain - Stainless steel



Pressure range

D = 0,2..3 bar
H = 0,5..10 bar

Options**

A00 = Without option
101 = Side Mounting Brackets
102 = Panel Nut
103 = Tamper resistant
104 = Key lockable
105 = High temperature (+80°C)
109 = FPM seals
113 = Stainless steel fasteners (652 only)
114 = Provision for key lock
117 = ATEX zones 1-21
119 = Panel Bracket with Panel Nut
121 = Non-relieving
123 = Gauge type mounted for right-to-left flow
202 = 105 + 109

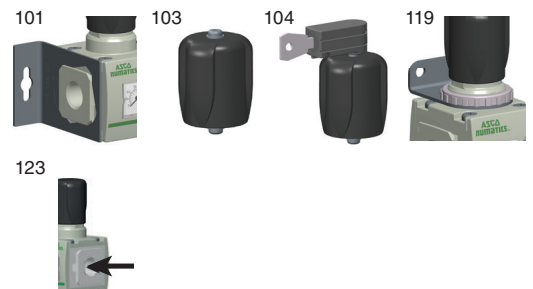

* Conforms to ISO standards 1179-1.

** If multiple options are required, please use the on-line CAD configurator on the website to generate the part number (www.asco.com).

Dimensions: mm

Dimensional Drawing - 651/652 Series Coalescing Filter/Regulator

[Configurator - CAD Files](#)

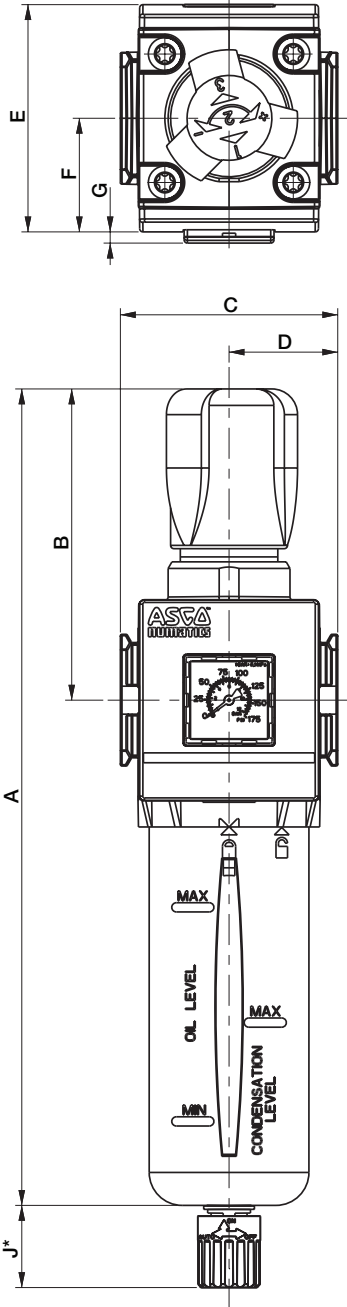

Cross Section - 651/652 Series Coalescing Filter/Regulator

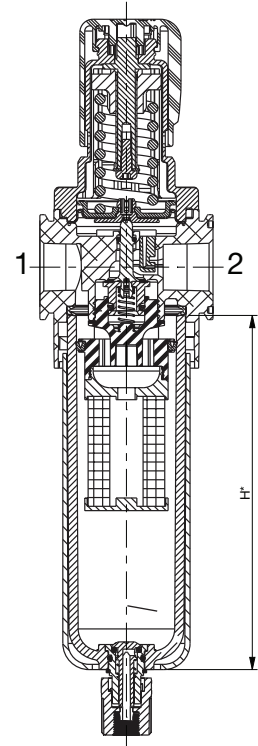

To remove bowl allow:
651 - 60 mm
652 - 80 mm
from the bottom
of the bowl drain.

Series	A	B	C	D	E	F	G	H	J
651	215,5	77,5	50	25	58	29	3,4	116	25
652	248	94,5	66	33	69	30,5	2,5	135	25

* Variable dimension based on type of drain that is specified. If an Automatic Drain is specified, add another 5 mm to "J" dimension.

01806GB-2016/R01
Availability, design and specifications are subject to change without notice. All rights reserved.

All leaflets are available on: www.asco.com

Coalescing Filter/Regulator Flow Charts

651 Filter-Regulator | 0.3µ Filtration | 1/8 Ports
P1 = 10 Bar (145 PSIG)

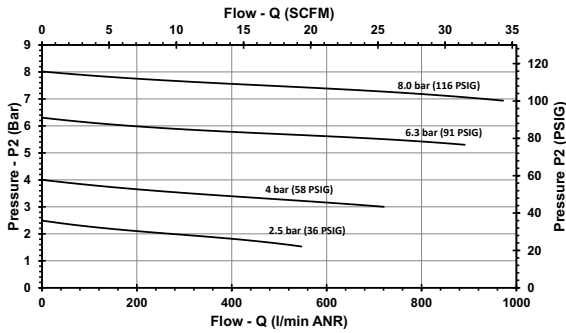

651 Filter-Regulator | 0.3µ Filtration | 1/4 Ports
P1 = 10 Bar (145 PSIG)

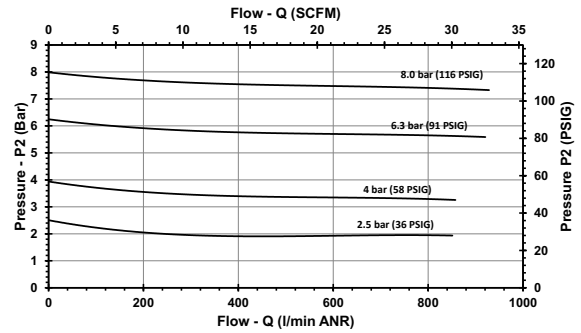

652 Filter-Regulator | 0.3µ Filtration | 1/4 Ports
P1 = 10 Bar (145 PSIG)

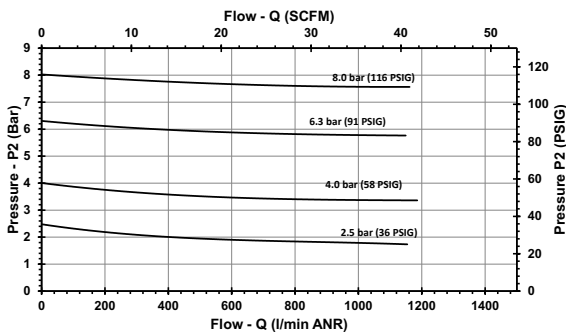

652 Filter-Regulator | 0.3µ Filtration | 3/8 Ports
P1 = 10 Bar (145 PSIG)

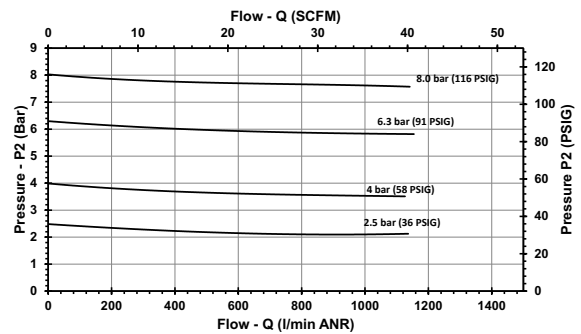

652 Filter-Regulator | 0.3µ Filtration | 1/2 Ports
P1 = 10 Bar (145 PSIG)

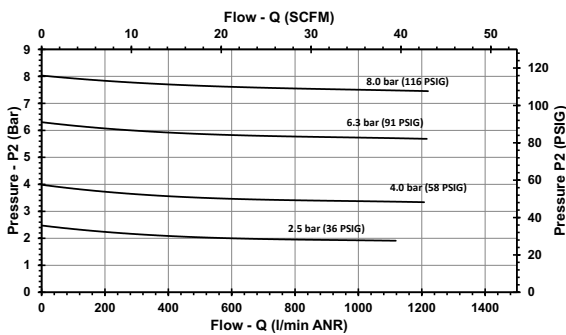

- Provides consistent reliable lubrication to the system
- Uses venture type technology to distribute the lubrication into the compressed air line
- Low flow is required to start lubrication
- Optional electronic liquid level indicator provides condition monitoring
- Allows fill while under pressure from fill port or bowl by removing the fill plug
- Recommended oil type: Non-detergent type and without aggressive additives (VG32 - ISO 3448)

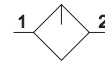

Performance Data			
Series	651		652
Port sizes	1/8, 1/4		1/4, 3/8, 1/2
Thread type	G (NPTF in option)		
Nominal flow - ISO 6358 P1 = 6,3 bar ΔP = 0,8 bar		l/min (ANR)	l/min (ANR)
	1/8	900	-
	1/4	1940	2780
	3/8	-	5000
	1/2	-	5100
Maximum pressure (bar)	Polycarbonate bowl	10	
	Aluminium bowl	10	
Minimum flow for lubrication - (l/min)	4,5		20
Ambient temperature range (°C)	+5 to +50		
Fluid temperature range (°C)	+5 to +50		
Fluid	air or inert gas		
Bowl Capacity (cm ³)		42	72
Fill Level Volume (ml)		45	80
Weight (kg)	w/Polycarbonate bowl	0,240	0,526
	w/Aluminium bowl	0,334	0,667

Materials in contact with fluid	
Body	Aluminium
Body covers	Polyamide
Seals	NBR

01807GB-2016/R01
Availability, design and specifications are subject to change without notice. All rights reserved.

All leaflets are available on: www.asco.com

HOW TO ORDER

Lubricator

G 651 A L 0 P 2 0 A00 0 0

[Configurator - CAD Files](#)

Thread connection

G = ISO 228/1-G*
8 = NPTF

Product series

651
652

Revision letter

A

Product type

L = Lubricator

Bowl Type

K = Metal Bowl without Sight Gauge
L = Metal bowl with sight gauge (glass)
P = Polycarbonate bowl with bowl guard

K/L

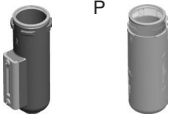

Options**

A00 = Without option
101 = Side Mounting Brackets
108 = Liquid Level Indicator - Electronic
109 = FPM seals
117 = ATEX zones 1-21

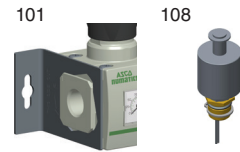

Port size

1 = 1/8 (651 Series)
2 = 1/4 (651 or 652 Series)
3 = 3/8 (652 Series)
4 = 1/2 (652 Series)

* Conforms to ISO standards 1179-1.

** If multiple options are required, please use the on-line CAD configurator on the website to generate the part number (www.asco.com).

Dimensions: mm

Dimensional Drawing - 651/652 Series Lubricator

[Configurator - CAD Files](#)

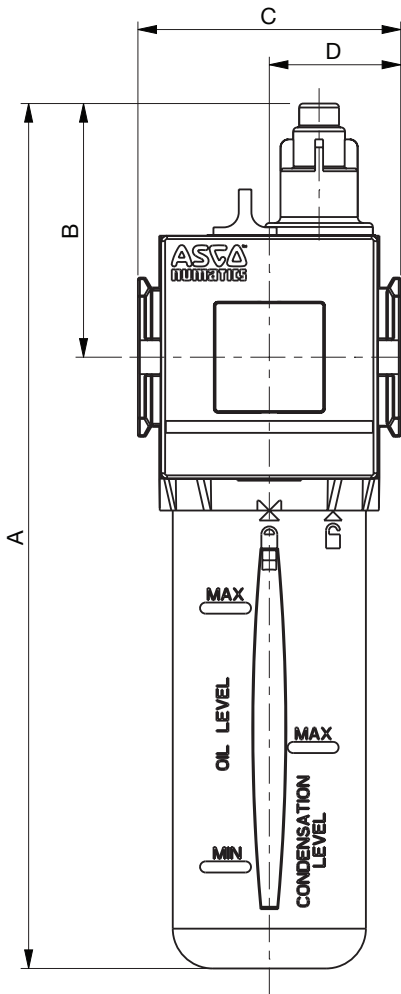
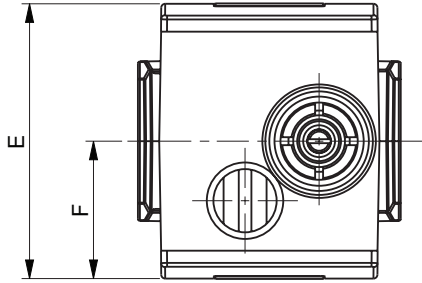

Cross Section - 651/652 Series Lubricator

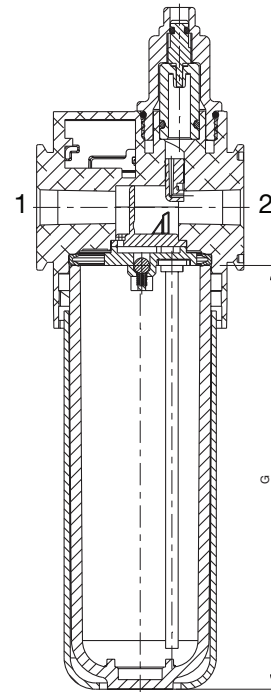

To remove bowl allow:
651 Series - 20 mm
652 Series - 25 mm
from the bottom of the bowl.

Series	A	B	C	D	E	F	G
651	198	58	50	25	58	29	116
652	217	64	66	33	69	30,5	135

01807GB-2016/R01
Availability, design and specifications are subject to change without notice. All rights reserved.

All leaflets are available on: www.asco.com

SHUT-OFF ISOLATION VALVE

- Robust and easy-to-operate shut-off valve, with lockout on handle
- Provides shut-off to downstream machinery
- Optional low profile integrated gauge provides clear indication of the downstream pressure, and when the downstream components can be safely removed when pressure (P2) is at zero
- Available as 3/2 or 2/2 construction

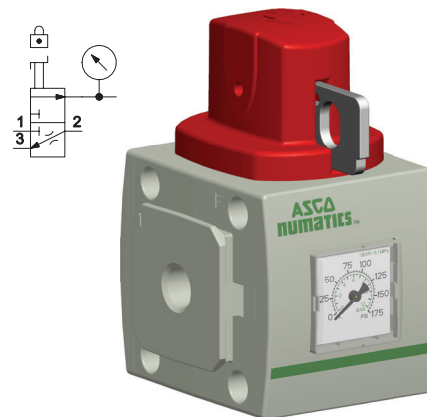

Performance Data					
Series	651		652		
Port sizes	1/8, 1/4		1/4, 3/8, 1/2		
Thread type	G (NPTF in option)				
Nominal flow - ISO 6358 P1 = 6,3 bar ΔP = 1 bar	l/min (ANR)		l/min (ANR)		
	1 → 2	2 → 3	1 → 2	2 → 3	
	1/8	1440	250	-	-
	1/4	4720	250	4300	230
	3/8	-	-	8800	230
1/2	-	-	11400	230	
Maximum inlet pressure (bar)	16				
Ambient temperature range (°C)	-10 to +50				
Fluid temperature range (°C)	-10 to +50				
Fluid	air or inert gas				
Weight (kg)	0,260		0,438		

Materials in contact with fluid	
Body	Aluminium
Body covers	Polyamide
Ball	Zinc plated steel
Seat	PTFE
Seals	NBR

HOW TO ORDER

Shut-Off Isolation Valve

G 651 A 3 M 0 2 G A00 00

[Configurator - CAD Files](#)

Thread connection
G = ISO 228/1-G*
8 = NPTF

Product series
651
652

Revision letter
A

Product type
2 = 2/2 - Shut Off Valve
3 = 3/2 - Shut Off Valve

Valve Type
M = Manually Operated Ball Valve with Lockout

Pilot valve/Electrical connection
0 = No Electrical Connection

Port size
1 = 1/8 (651 Series)
2 = 1/4 (651 or 652 Series)
3 = 3/8 (652 Series)
4 = 1/2 (652 Series)

* Conforms to ISO standards 1179-1.

** [If multiple options are required, please use the on-line CAD configurator on the website to generate the part number \(www.asco.com\).](#)

Options**

- A00 = Without option
- 101 = Side Mounting Brackets
- 109 = FPM seals
- 111 = Metal Muffler
- 112 = Polyethylene Muffler
- 113 = Stainless steel fasteners
- 115 = Scissor Lock
- 117 = ATEX zones 1-21 
- 122 = Bottom oriented pressure adjustment
- 123 = Gauge type mounted for right-to-left flow
- 2B9 = 111 + 115



Gauge type

- G = Low profile integrated gauge bar/PSI
- J = Low profile integrated gauge bar/PSI with pressure range indicators
- Q = Round gauge bar/PSI
- 0 = No gauge port
- P = Port Plate Rc 1/8

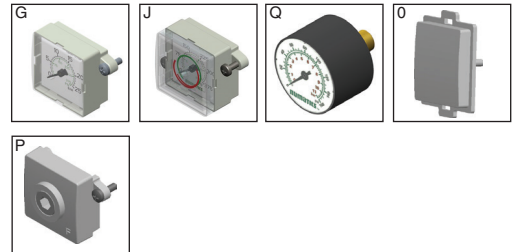

Dimensions: mm

Dimensional Drawing - 651/652 Series Shut-Off Isolation Valve

[Configurator - CAD Files](#)

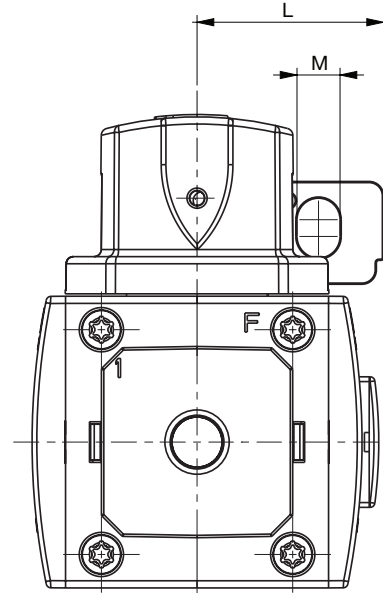
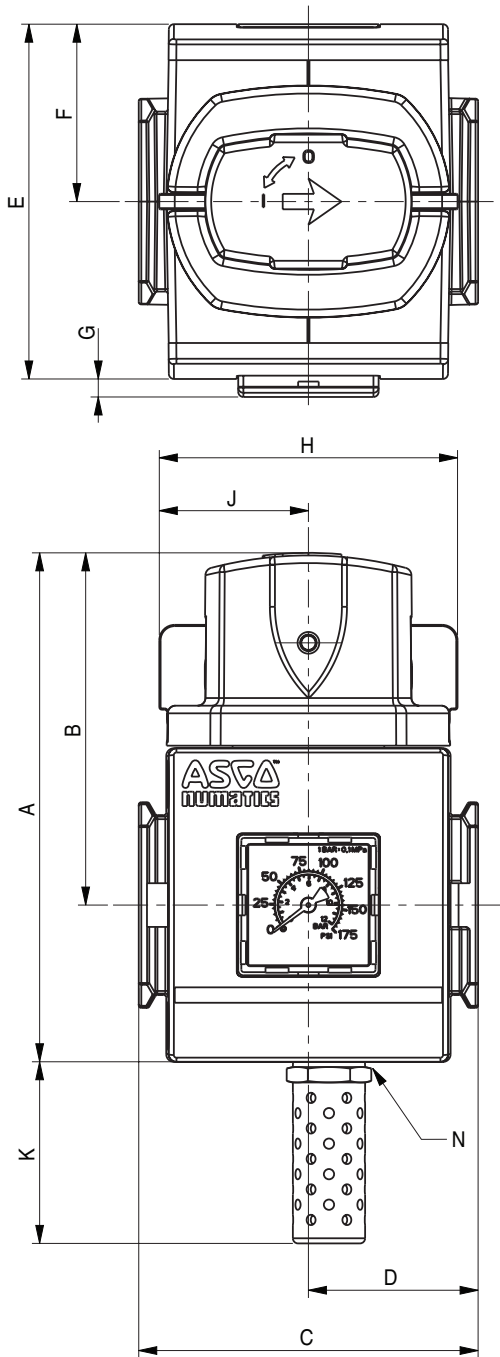

Cross Section - 651/652 Series Shut-Off Isolation Valve

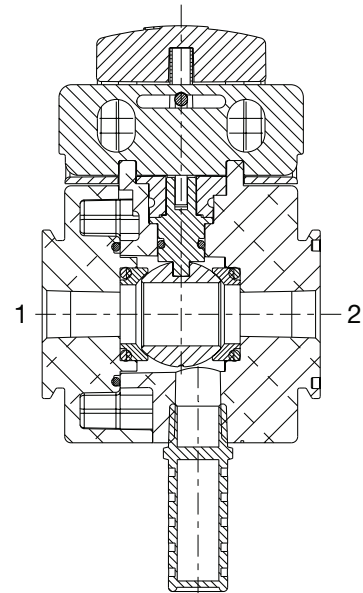

Series	A	B	C	D	E	F	G	H	J	K	L	M	N
651	90,5	65,5	50	25	58	29	4,4	57,8	28,9	35,5	38	9	G1/4
652	99	68	66	33	69	34,5	2,5	58	29	35	39	9	G1/4

- This unit provides two main functions:
 - Pneumatic system venting
 - Gradual pressurisation after an outage leading to venting of the system
- This product allows for machines and installations to conform to the European Directives
- High exhaust capacity for quick depletion of downstream pressure
- Optional low profile integrated gauge, round gauge, digital gauge or digital pressure switch
- Constructions includes: 3/2 Quick Exhaust, 3/2 Slow-Start/Quick-Exhaust, and 2/2 Slow Start
- Electrical connections: Coil with DIN terminals; DIN Plug, DIN Plug with LED, and coil with built-in M12 3 Pin male connection (24 VDC)

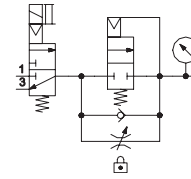
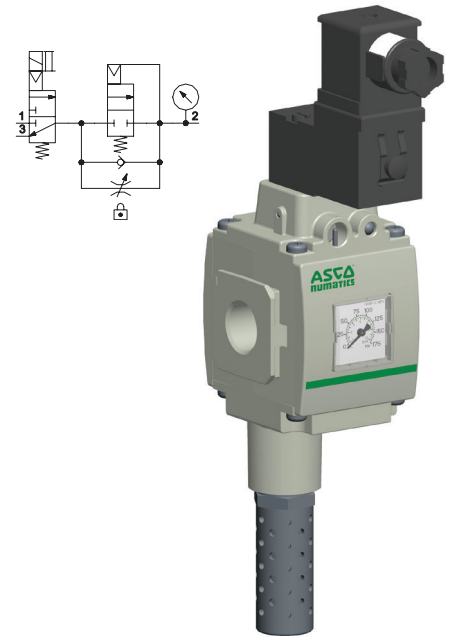

Performance Data					
Series	651		652		
Port sizes	1/8, 1/4		1/4, 3/8, 1/2		
Thread type	G (NPTF in option)				
Nominal flow - ISO 6358 P1 = 6,3 bar ΔP = 1 bar		l/min (ANR)		l/min (ANR)	
		1 → 2	2 → 3	1 → 2	2 → 3
	1/8	780	1040	-	-
	1/4	1000	1120	1500	2100
	3/8	-	-	3750	4300
	1/2	-	-	4650	5000
Minimum operating pressure (bar)	3,8				
Maximum operating pressure (bar)	10				
Ambient temperature range (°C)	-10 to +50				
Fluid temperature range (°C)	-10 to +50				
Fluid	air or inert gas				
Weight (kg)	0,387		0,438		

Materials in contact with fluid	
Body	Aluminium
Seals	NBR/FKM
Springs	Stainless steel

Operating Data				
	24/DC	115/50	230/50	24/50
Power	—	9 VA	9 VA	9 VA
Holding	3 W	4 VA (3 W)		

System Pressurization and Depressurization Curves (with Automatic Soft-Start Device)

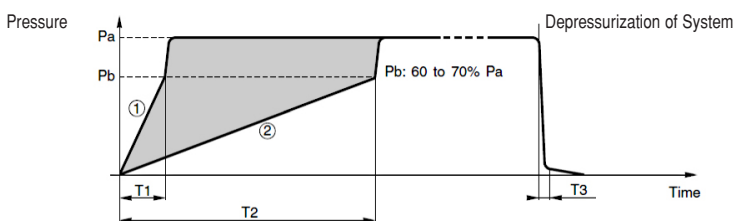

The adjustment range for the pressurization time lies between curves (1) and (2).

The transition to full flow takes place automatically as soon as the downstream pressure reaches 60 to 70% of the upstream pressure.

Filling and venting times (seconds)		
	651 Series	652 Series
T1 (with screw loosened by 7 turns)	8	3
T2 (with screw loosened by 1 turn)	112	23
T3 (venting time)	5	1

These times correspond to a supply pressure (Pa) of 6.3 bar, a transition pressure (Pb) of 60 to 70% Pa (not adjustable) and a downstream system volume of 10 liters.

All leaflets are available on: www.asco.com

01809GB-2017/R01 Availability, design and specifications are subject to change without notice. All rights reserved.

HOW TO ORDER

Slow Start-Quick Exhaust Valve

G 651 A 6 S 6 2 G A00 F1

[Configurator - CAD Files](#)

Thread connection

- G = ISO 228/1-G*
- 8 = NPTF

Product series

- 651
- 652

Revision letter

- A

Product type

- 4 = 2/2 - Slow start
- 5 = 3/2 - Quick exhaust
- 6 = 3/2 - Slow start/Quick exhaust

Valve type

- E = External air pilot
- P = Internal air pilot
(Available on 2/2 Slow Start only)
- S = Solenoid air pilot

Pilot valve/Electrical connection

- 0 = No Electrical Connection
- 1 = 189 Series Vertical Solenoid Pilot, without DIN Connector (must order with option 110)
- 2 = 189 Series Vertical Solenoid Pilot, DIN Connector with LED (must order with option 110)
- 3 = 189 Series Vertical Solenoid Pilot, DIN Connector w/o LED (must order with option 110)
- 4 = 189 Series Vertical Solenoid Pilot, 3 Pin M12 Connection** (must order with option 110)
- 5 = 190 Series Horizontal Solenoid Pilot, without DIN Connector
- 6 = 190 Series Horizontal Solenoid Pilot, DIN Connector with LED
- 7 = 190 Series Horizontal Solenoid Pilot, DIN Connector without LED
- 8 = 190 Series Horizontal Solenoid Pilot with 3 Pin M12 Connection**
- 9 = Without pilot operator

Port size

- 1 = 1/8 (651 Series)
- 2 = 1/4 (651 or 652 Series)
- 3 = 3/8 (652 Series)
- 4 = 1/2 (652 Series)

* Conforms to ISO standards 1179-1.

** Available for DC voltage only.

*** If multiple options are required, please use the on-line CAD configurator on the website to generate the part number (www.asco.com).

**** Option 117 (ATEX 1-21) is available with Valve Type "E" or "P". For Valve Type "S" (Solenoid Pilot), please select "9" under the "Pilot Valve/Electrical Connection. Contact us for further information.

Voltage

- EW = 115 50/60 VAC
- F1 = 24 VDC
- FQ = 24 50/60 VAC
- FH = 230 50/60 VAC
- 00 = No voltage

Options***

- A00 = Without option
- 101 = Side Mounting Brackets
- 109 = FPM seals
- 110 = Without manual operator
- 111 = Metal Muffler
- 112 = Polyethylene Muffler
- 113 = Stainless steel fasteners
- 117 = ATEX zones 1/21 ****
- 122 = Inverter Mounting
- 123 = Gauge type mounted for right-to-left flow
- 201 = 110 + 111



Gauge type

- B = Digital pressure switch - PNP
- C = Digital pressure switch - NPN
- D = Digital gauge
- G = Low profile integrated gauge bar/PSI
- J = Low profile integrated gauge bar/PSI with pressure range indicators
- Q = Round gauge bar/PSI
- 0 = No gauge port
- P = Port Plate Rc 1/8

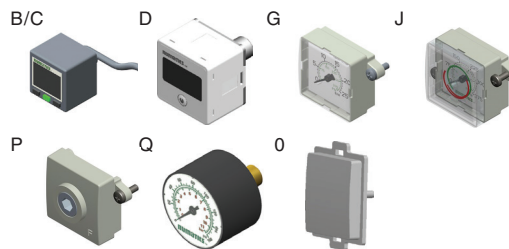

Dimensions: mm

Dimensional Drawing - 651/652 Series Slow-Start/Quick Exhaust Valve

[Configurator - CAD Files](#)

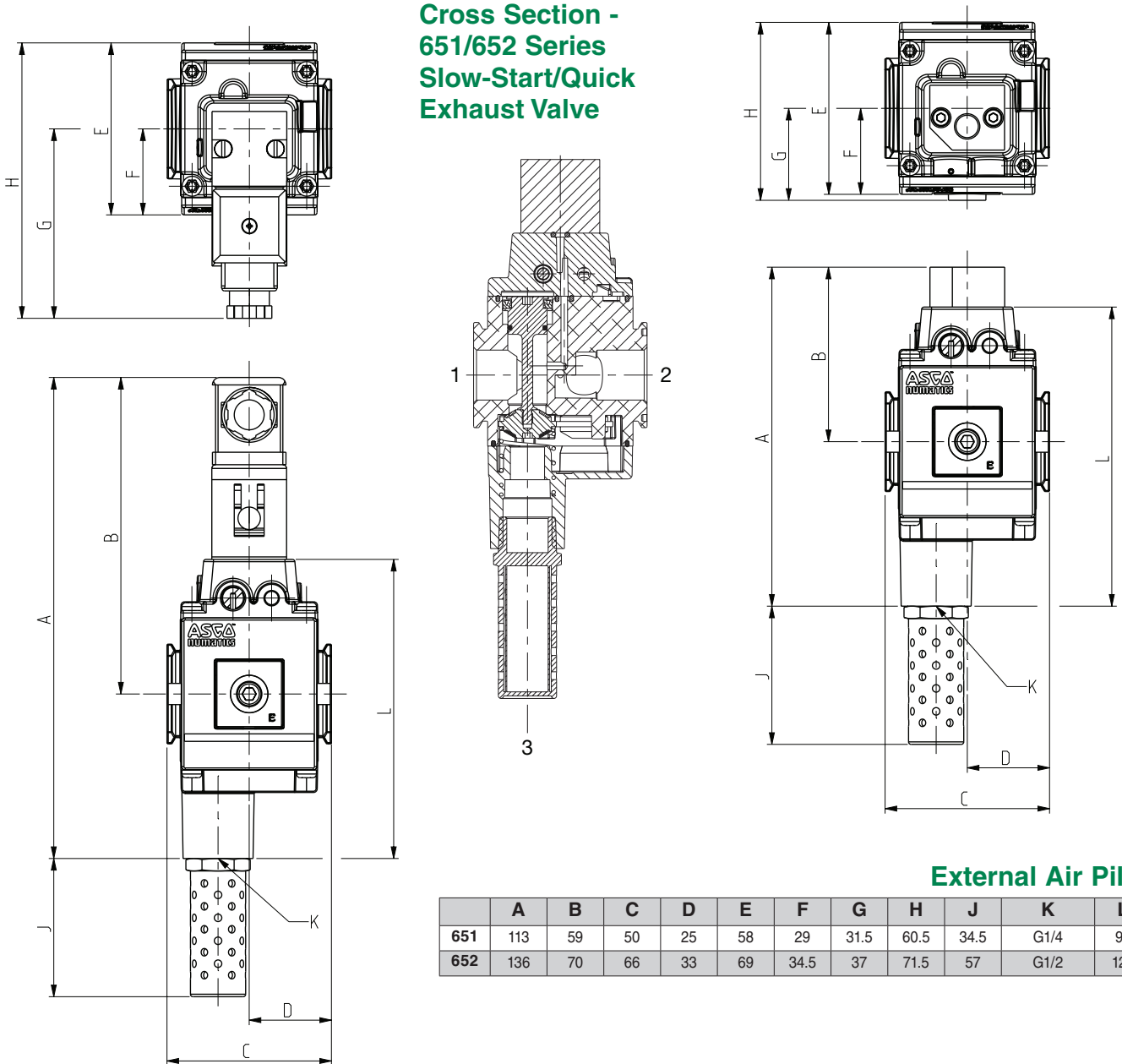

External Air Pilot

	A	B	C	D	E	F	G	H	J	K	L
651	113	59	50	25	58	29	31.5	60.5	34.5	G1/4	97
652	136	70	66	33	69	34.5	37	71.5	57	G1/2	120

Solenoid Pilot

Series	A	B	C	D	E	F	G	H	J	K
651	170	116	50	25	58	29	72	101	34,5	G1/4
652	193	127	66	33	69	34,5	76	110,5	57	G1/2

01809GB-2016/R01
Availability, design and specifications are subject to change without notice. All rights reserved.

All leaflets are available on: www.asco.com

- Ideal for branching off primary 651/652 series air prep manifold to add additional products
- 1/4 G (651) or 3/8 G (652) ports on the front and back provide additional flexibility to attach or branch off the main manifold
- It can also be used to feed auxiliary air to air prep assemblies that require additional air capacity, such as a bank of manifold regulators



Performance Data			
		651	652
Port sizes	Left, Right & Bottom	1/4 & flange	1/2 & flange
	Front & Back	1/4	3/8
Thread type		G (NPTF in option)	
Top Port (for Pressure Switch/Pressure Sensor)		pad mount	
Maximum pressure (bar)		16	
Fluid		air or inert gas	
Weight (kg)		0,188	0,331

Materials in contact with fluid	
Body	Aluminium
Body covers	Polyamide

HOW TO ORDER

Diverter Block

G 651 A D 0 0 2 C A00 0 0

[Configurator - CAD Files](#)

Thread connection

G = ISO 228/1-G*
8 = NPTF

Product series

651
652

Revision letter

A

Product type

D = Diverter Block

Options*

A00 = Without option
101 = Side Mounting Brackets
117 = ATEX zones 1-21

Pressure switch interface

C = Provisioned for 349 pressure switch pad mount

Port size

2 = 1/4 (651 Series)
4 = 1/2 (652 Series)

* If multiple options are required, please use the on-line CAD configurator on the website to generate the part number (www.asco.com).

Dimensions: mm

Dimensional Drawing - 651/652 Series Diverter Block

[Configurator - CAD Files](#)

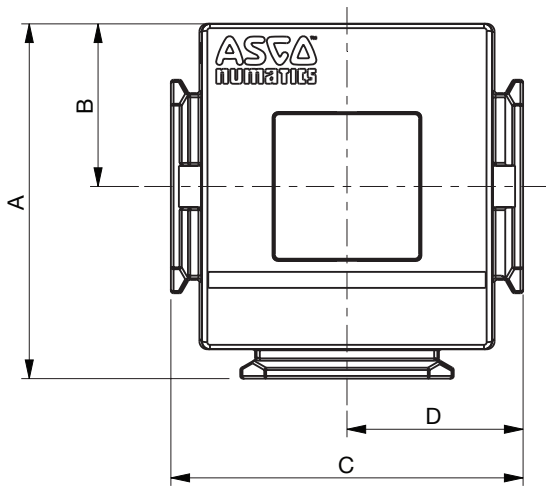
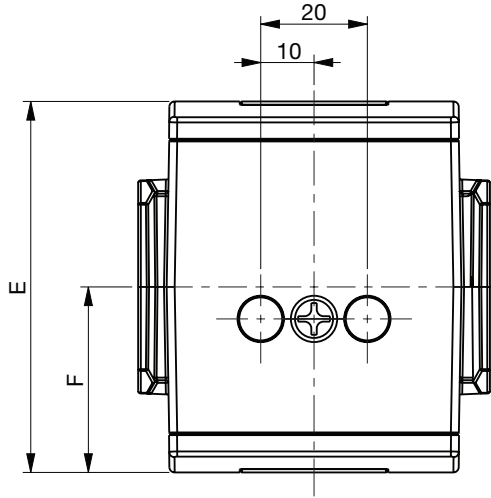

Cross Section - 651/652 Series Diverter Block

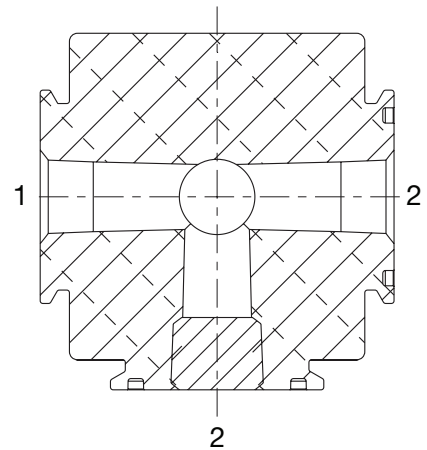

Series	A	B	C	D	E	F	G	H
651	54,4	25	50	25	58	29	10	20
652	66.5	30,5	66	33	70	35	10	20

01810GB-2016/R01
Availability, design and specifications are subject to change without notice. All rights reserved.

All leaflets are available on: www.asco.com

- Modular assembly to 652 series manifold using common 652 series body clamps
- Provides high exhaust capacity of downstream pressure
- Available as full-flow start or slow-start
- Slow-start feature allows operator to turn knob counter clock wise to “On” position, gradually ramping up downstream pressure
- Bright yellow body with red knob is easily identified as an emergency shut-off device
- Typically located as the final component in an FRL manifold

3/2 Lockout Valve with Slow Start Feature

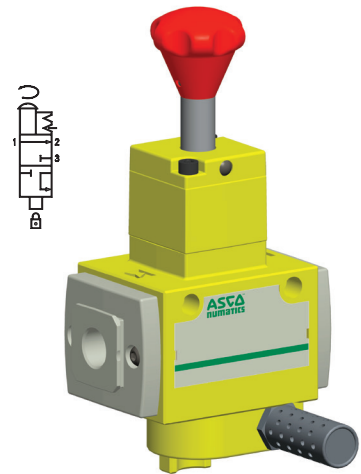

3/2 Lockout Valve



Performance Data		
Port sizes*	1/2	
Nominal flow		1 → 2
	l/min (ANR)	5910
		2 → 3
		5910
Ambient temperature range (°C)	+4 to +50	
Fluid temperature range (°C)	+4 to +50	
Maximum pressure (bar)	10,3	
Fluid	air or inert gas	
Weight (kg)	Standard	1,23
	Slow Start	1,39

*Ports are not threaded (grey Flanges). Easily connect to 652 Series Manifold. When connecting to pipe, use end-plate kits #T652AT502468002

Materials in contact with fluid	
Body	Aluminium
Seals	NBR
Spool	Aluminium

HOW TO ORDER

Lockout Valve

T 652 A 5 L 0 4 0 A00 00

Thread connection
T = Modular Mounting

Product series
652

Revision letter
A

Product type
5 = 3/2 - Quick Exhaust
6 = 3/2 - Slow Start - Quick Exhaust

[Configurator - CAD Files](#)

Options*
A00 = Without option
111 = Metal Muffler
115 = Scissor Lock
2B9 = 111 + 115

Port size
1/2

Valve Type
L = Manually Operated Lockout

* If multiple options are required, please use the on-line CAD configurator on the website to generate the part number (www.asco.com).

Dimensions: mm

Dimensional Drawing - 652 Series Lockout Valve

[Configurator - CAD Files](#)

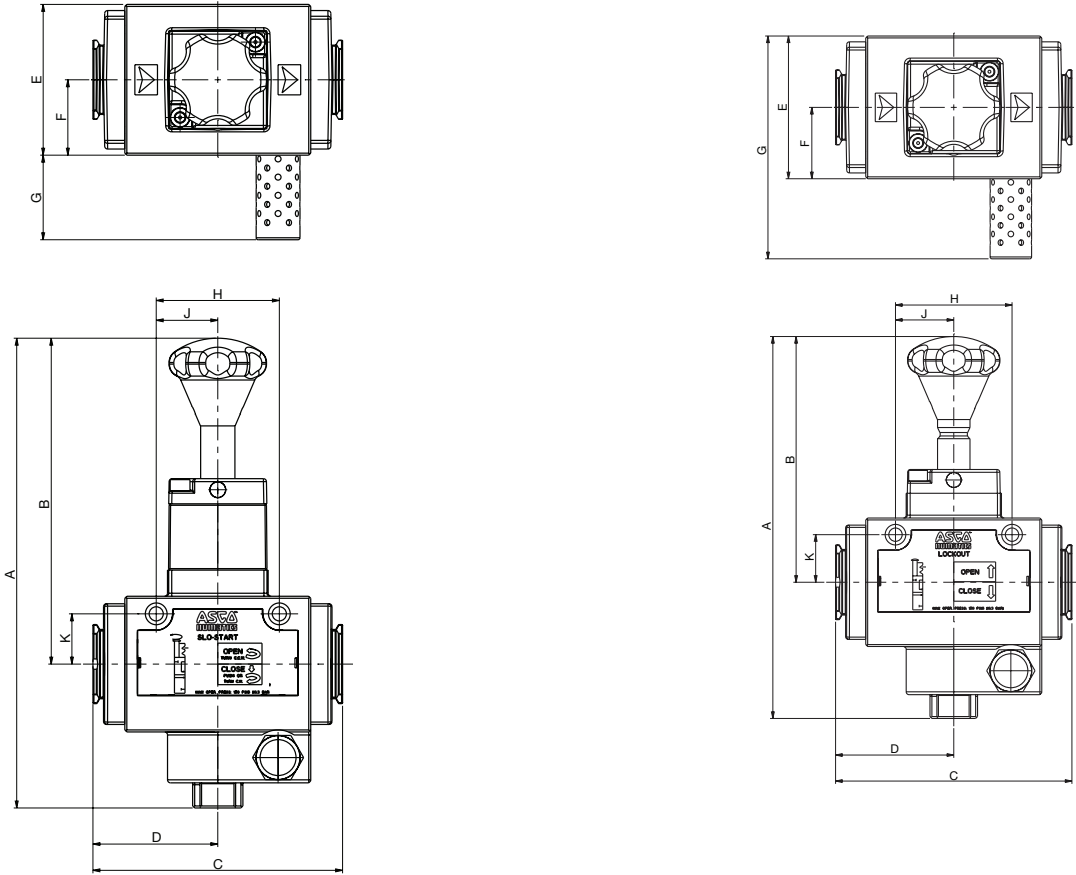

Note: When the knob is pushed down (Closed position), the lockout shaft extends out of the bottom by 12,2 mm. The lockout hole diameter in the shaft is 11,2 mm. These measurements are the same for the standard Lockout and the Slow-Start version.

3/2 Lockout Valve with Slow Start Feature

A	B	C	D	E
237,5	164,9	126,2	63,1	76,2
F	G	H	J	K
38,1	42,7	62,2	31,1	25,4

3/2 Lockout Valve

A	B	C	D	E
204	131,3	126,2	63,1	76,2
F	G	H	J	K
38,1	119	62,2	31,1	25,4

3/2 Lockout Valve with Slow Start Feature Cross Section

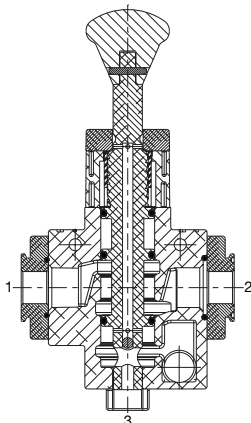

3/2 Lockout Valve Cross Section

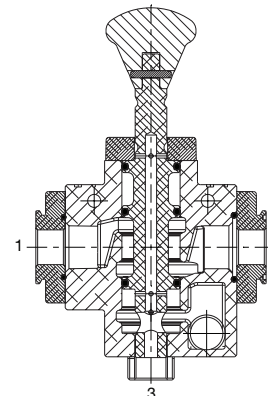

01811GB-2016/R01
Availability, design and specifications are subject to change without notice. All rights reserved.

All leaflets are available on: www.asco.com

FR + L AIR PREPARATION MANIFOLD ASSEMBLIES

- Assembly of Filter/Regulator + Lubricator to meet most frequent configurations
- Filter/Regulator with low profile integrated gauge
- Polycarbonate bowls with bowl guard
- Delivered mounted and tested, saves time and logistic costs



[Configurator - CAD Files](#)

Performance Data				
		Series		
Port sizes*		651	1/4	
		652	1/2	
Thread type			G (NPTF in option)	
Micron Rating			25 µm	5 µm
			Part Number	Part Number
Semi-Automatic & Manual Drain:				
Adjustable Pressure: 0,2-10 bar				
	1/8	651	A651A0000000400	A651A0000000408
	1/4	651	A651A0000000401	A651A0000000409
		652	A652A0000000001	A652A0000000013
	3/8	652	A652A0000000002	A652A0000000014
	1/2	652	A652A0000000003	A652A0000000015
Adjustable Pressure: 0,2-3 bar				
	1/8	651	A651A0000000402	A651A0000000410
	1/4	651	A651A0000000403	A651A0000000411
		652	A652A0000000004	A652A0000000016
	3/8	652	A652A0000000005	A652A0000000017
	1/2	652	A652A0000000006	A652A0000000018
Automatic Drain:				
Adjustable Pressure: 0,2-10 bar				
	1/8	651	A651A0000000404	A651A0000000412
	1/4	651	A651A0000000405	A651A0000000413
		652	A652A0000000007	A652A0000000019
	3/8	652	A652A0000000008	A652A0000000020
	1/2	652	A652A0000000009	A652A0000000021
Adjustable Pressure: 0,2-3 bar				
	1/8	651	A651A0000000406	A651A0000000414
	1/4	651	A651A0000000407	A651A0000000415
		652	A652A0000000010	A652A0000000022
	3/8	652	A652A0000000011	A652A0000000023
	1/2	652	A652A0000000012	A652A0000000024

Dimensions: mm

Dimensional Drawing - 651/652 Series Filter/Regulator + Lubricator

[Configurator - CAD Files](#)

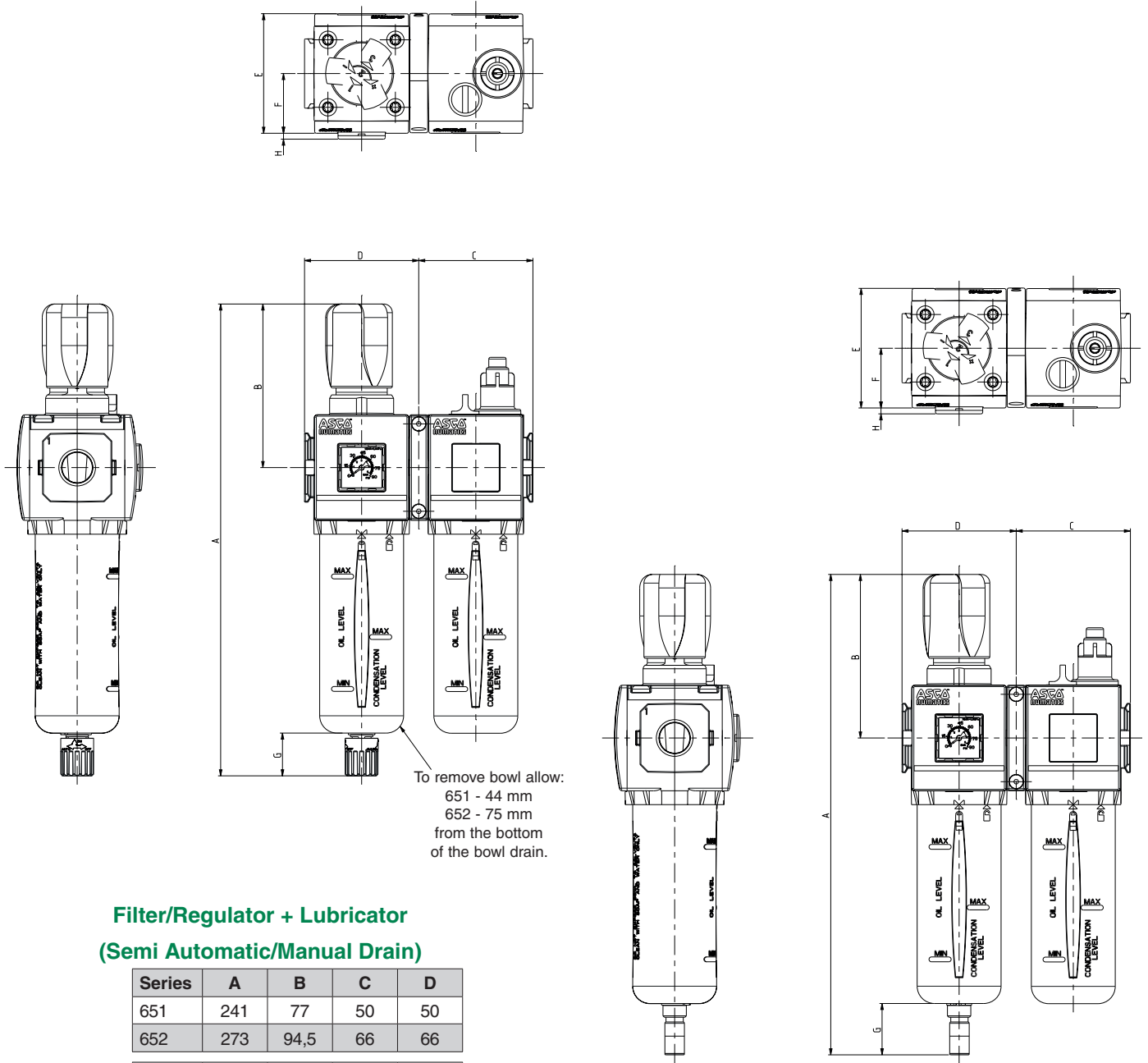

**Filter/Regulator + Lubricator
(Semi Automatic/Manual Drain)**

Series	A	B	C	D
651	241	77	50	50
652	273	94,5	66	66

Series	E	F	G	H
651	56	29	25	3,5
652	69	34,5	25	3,4

**Filter/Regulator + Lubricator
(Automatic Drain)**

Series	A	B	C	D
651	246	77	50	50
652	277,5	94,5	66	66

Series	E	F	G	H
651	56	29	30	3,5
652	69	34,5	29,5	3,4

01812GB-2016/R01
Availability, design and specifications are subject to change without notice. All rights reserved.

All leaflets are available on: www.asco.com

Dimensions: mm

Dimensional Drawing - Mounting Options

651 Series Side Mounting Brackets Kit: P651AT503860001

652 Series Side Mounting Brackets Kit: P652AT503860002

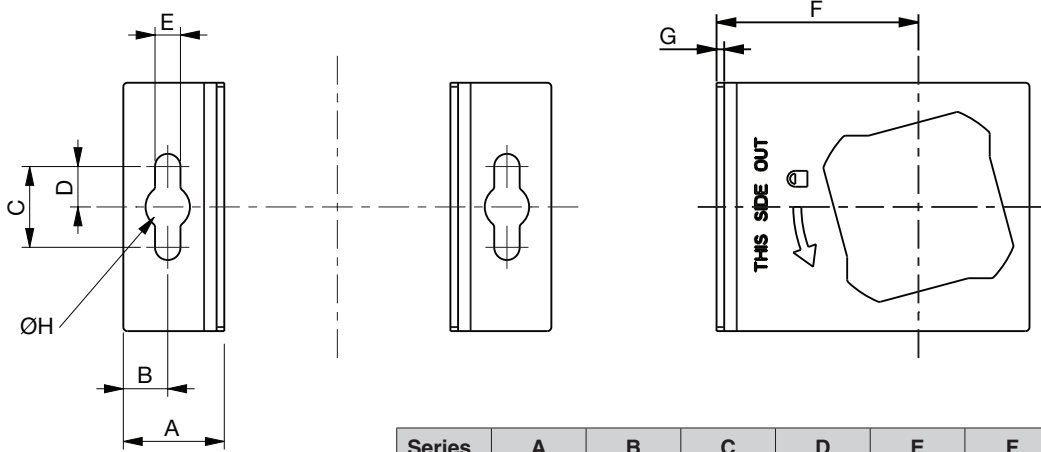

Series	A	B	C	D	E	F	G	ØH
651	25	11	20	10	6,3	44,5	1,27	11
652	25	11	20	10	6,3	50	1,9	11

Wall/Panel Bracket Kit: P699AT502467001 (651/652)

A	B	C	D
26	13	92	46
E	F	G	ØH
6	3	6,5	6,5
J	K	L	M
8	18	109	44,5

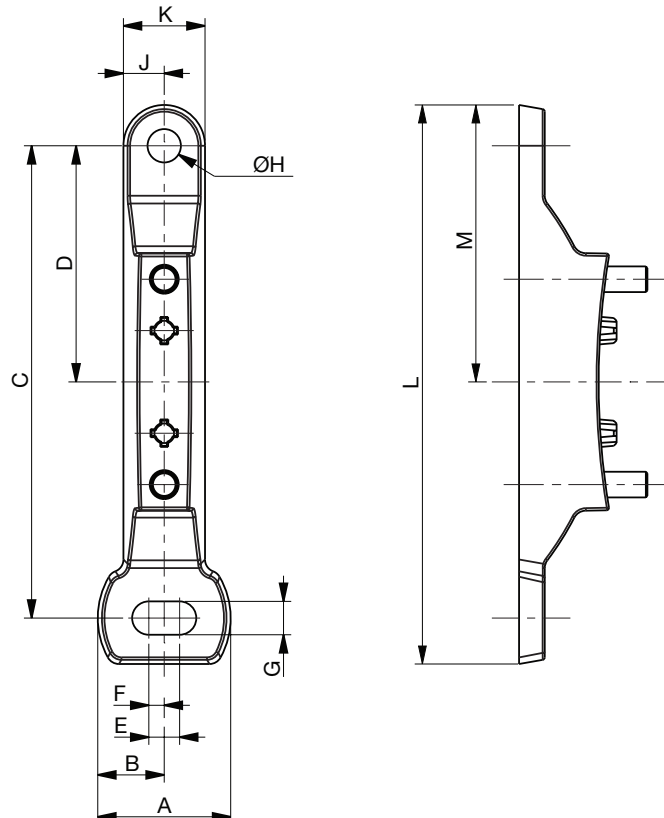

BOWLS

Dimensions: mm

Dimensional Drawings - Bowl Drain Options

Polycarbonate Bowl/Guard with Semi-Automatic/Manual Drain

Polycarbonate Bowl/Guard with Stainless Steel Manual Drain

Metal Bowl with Automatic Drain

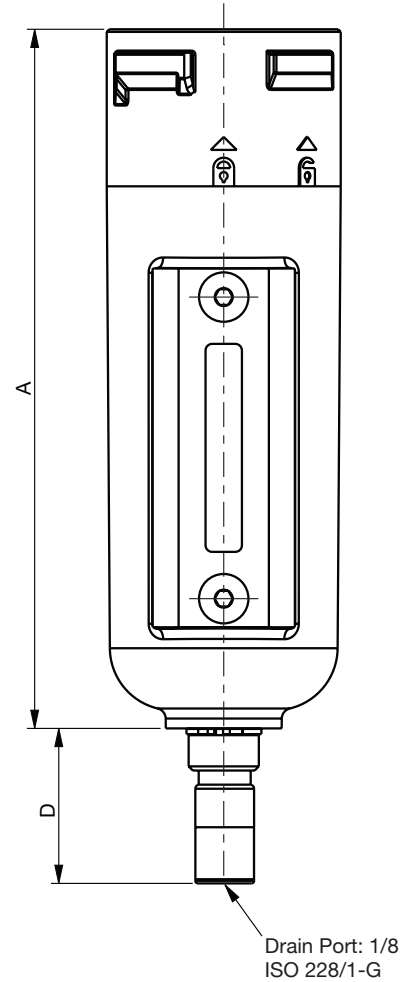
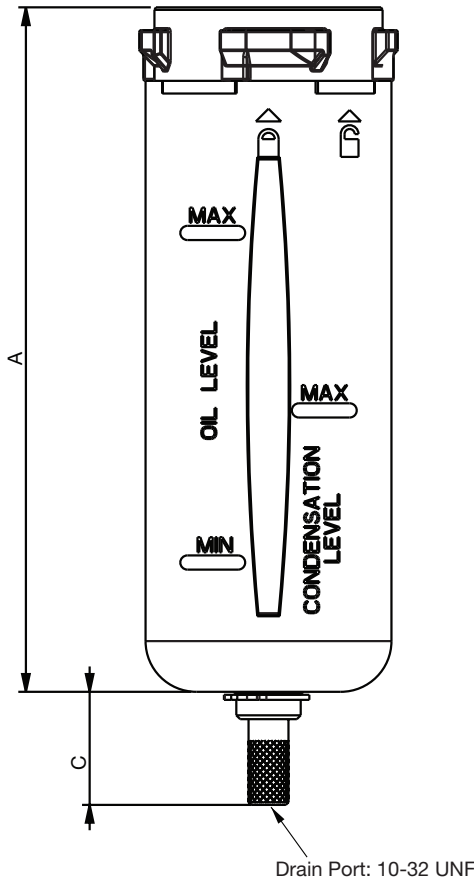
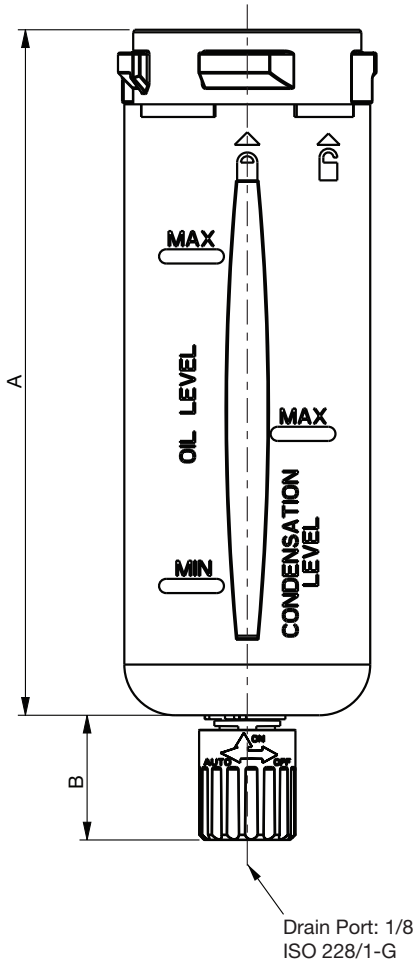

Please allow the following mm clearance for bowl removal:

Series	A	B	C	D
651	116	25	22,5	30
652	135	25	22,3	30

	651	652
Particulate Filter or Filter/Reg (from bottom of drain)	44	75
Coalescing Filter or Filter/Reg (from bottom of drain)	60	80
Lubricator (from bottom of bowl)	20	25

Bowl Type	Series	Filter - Max Condensate Level (ml)				Lubricator - Max Oil Level (ml)	
		Semi/Manual	Manual	Automatic	No Drain	No Option	w/Liquid Level Indicator
Polycarbonate	651	30	30	15	30	45	35
	652	50	50	35	50	90	80
Aluminium	651	30	30	15	30	45	35
	652	50	50	35	50	90	80

01813GB-2016/R01
Availability, design and specifications are subject to change without notice. All rights reserved.

All leaflets are available on: www.asco.com

280 Series Digital Pressure Switch

Performance Data	
Port Size/Thread Type	1/8 ISO 7/1 Rc Male x M5-0,8 Female
	1/8 NPTF Male x 10/32 UNF Female
Ambient Temperature Range (°C)	0 to +50
Rated Pressure Range (bar)	0 to 10
Maximum pressure (bar)	15
Fluid	air or inert gas
Set Pressure Resolution	kPa 1
	kgf/cm ² 0,01
	bar 0,01
	PSI 0,1
LCD Display	7 Segment; Red/Green Color
Sampling Rate	5 times per second
Repeatability	≤ +/- 0,2% F.S. +/- 1 Digit
Hysteresis (window comparator mode)	Adjustable
Electrical Ratings	
Power Supply Voltage	12 to 24 VDC +/- 10% Ripple (P-P) 10% or Less
Current Consumption	≤ 45 mA (with no load)
Switch Output	PNP Open Collector / NPN Open Collector
Max. Load Current	125 mA 125 mA
Max Supply Voltage	24 VDC 30 VDC
Residual Voltage	≤ 1,5 V ≤ 1,5 V
Load Current	125 mA 125 mA
Enclosure Rating	IP40
Materials in Contact with Fluid	
Enclosure Case	PBT + 30 GF
Port	Nickel Plated Brass
Seals	NBR

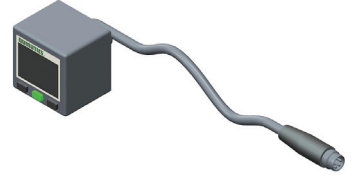

How to Order

Model Numbers

DPS280PRQ8 1/8 ISO 7/1 Rc (PNP) DPS280PNQ8 1/8 NPTF (PNP)
 DPS280NRQ8 1/8 ISO 7/1 Rc (NPN) DPS280NNQ8 1/8 NPTF (NPN)

Note: All part numbers include an 8 mm Pico 4 Pin connector and 2 meter cable (4 mm O.D. x 26 AWG)

Display Panel Instructions

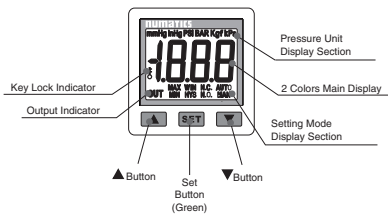

Switch Wiring

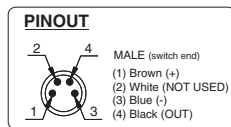

Output Circuit Wiring

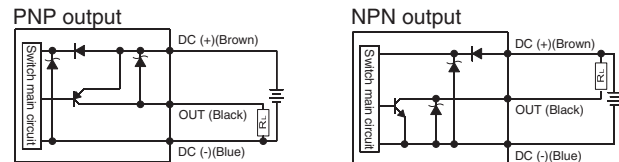

Accessory Numbers

Model	Accessory Description
DPS280-8-4-ST-2	Mating Cable 8 mm 4 Pin 2 Meter
DPS280-8-4-ST-5	Mating Cable 8 mm 4 Pin 5 Meter
PC0402MEETA03000	Patch Cable M8 4 Pin X M12 3 Pin 2 Meter

Model	Accessory Description
PMK280-C	Panel Mount Kit with Cover

PS180 Series Pressure Switch

Performance Data	
Port Size/Thread Type	ISO 228/1-G (BSPP) & 1/8 NPTF
Ambient temperature range (°C)	-15 to +85
Set Point Adjustment Ranges (bar)	0,28 to 1,38; 0,97 to 10,34
Maximum pressure (bar)	20,7
Fluid	air or inert gas
Maximum Cycle Rate per Minute	200
Hysteresis Adjustment	15%
Electrical Ratings	
Switch Contact Rating	4 A
Maximum Voltage	250 VAC (200 VDC)
Enclosure Rating	IP65
Materials in Contact with Fluid	
Connector Housing	Polyamide
Port	Zinc plated steel
Seals	NBR

How to Order

Model Numbers

PS180CAG01	1/8 ISO 228/1-G
PS180CAN01	1/8 NPTF

Digital Pressure Gauge

Performance Data	
Port Size/Thread Type	1/8 (ISO 7/1 Rc or NPTF)
Ambient temperature range (°C)	0 to +50
Rated Pressure Range (bar)	0 to 10
Maximum pressure (bar)	15
Fluid	air or inert gas
Display (Unit Measurement)	PSI, bar, Mpa, kgf/cm ²
LCD Display	7 Segment 3-1/2 Digit
Sampling Rate	2 times per second
Repeatability	< + 0.2% + 1 Digit
Electrical Ratings	
Battery	CR 2032 Lithium (Replaceable)
Battery Life	3 Year (display turned on 5 times per day)
Battery Power Saving Mode	Display turns off after 30 seconds
Enclosure Rating	IP65
Materials in Contact with Fluid	
Enclosure - Front Case	ABS
Enclosure - Back Case	Zinc
Seals	NBR

How to Order

Model Numbers

M699AG504650002	1/8 ISO 7/1
M699AG504650001	1/8 NPTF

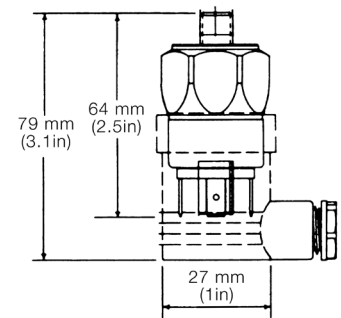
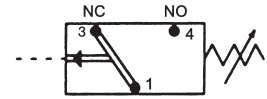

01814GB-2016/R01
Availability, design and specifications are subject to change without notice. All rights reserved.

All leaflets are available on: www.asco.com

349 Series Pressure Switch

Performance Data		
	Without Protection	With Protection
Port Size/Thread Type	Pad Mounted	
Fluid	air or inert gas	
Pressure Setting	0,2 to 6; 0,5 to 10; 0,5 to 16 bar	
Hysteresis	0,4 bar at the beginning of adjustment range 1 bar at the end of adjustment range	
Operating Temperature (°C)	-10 to +60	0 to +60
Max Voltage	250V - AC/DC	24 VDC
Current Breacking Capacity	5A - 250V Resistive	2A - 24VDC Resistive
Protection Degree	IP65	
Max Speed	60 cycles per minute	
Material in contact with fluid		
Body	High Performance Polymer(PA61/XT) / Aluminium for 16 bar version	
Seals	NBR	



How to Order

	0,2 - 6 bar	0,5 - 10 bar	0,5 - 16 bar
With Protection	34900028	34900031	34900034
Without Protection	34900027	34900030	34900033

Dimensional Drawings

Without Protection

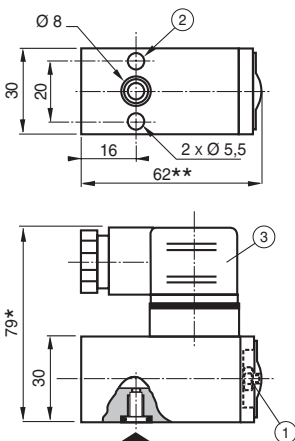

- ① Pressure set screw (spanner for hexagon nuts: 3 mm)
- ② 2 holes Ø 5,5 for mounting
- ③ ISO4400 size 30 connector, 4 terminals, rotatable by 90°

* +15 mm for connector clearance

** +2 mm for 0,5-16 bar version

With Protection

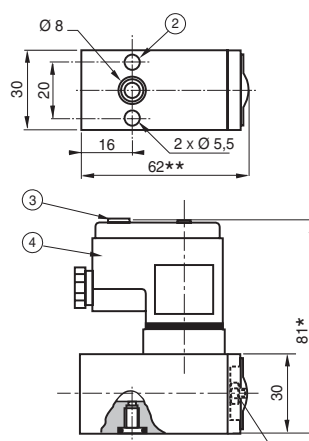

- ① Pressure set screw (spanner for hexagon nuts: 3 mm)
- ② 2 holes Ø 5,5 for mounting
- ③ Identification label holder
- ④ Pg9P connector, non rotatable

* +15 mm for connector clearance

** +2 mm for 0,5-16 bar version

With Protection Electrical Diagram

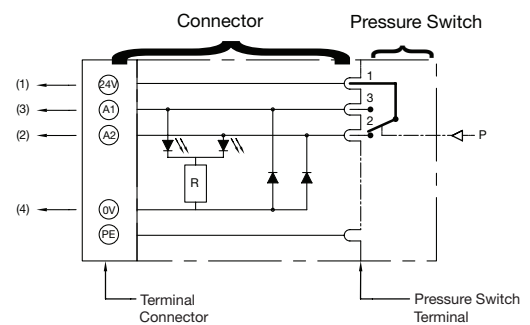

Status indicated by two diodes:

- at rest: contact 1-2 made: orange diode lights
 - at work: contact 1-3 made: red diode lights
- Terminal connection for 1,5 mm² wire integrated interference blinking

Electrical Connection With and Without Protection

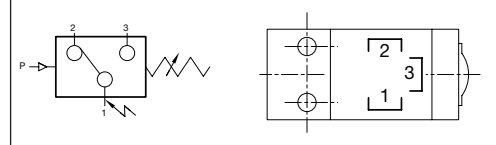

Electric Differential Pressure Indicator

Performance Data	
Ambient temperature range (°C)	-25 to +100
Maximum pressure (bar)	20
Delta P Setting (bar)	0,7
Electrical Ratings	
Switching Contact	SPDT
14 VDC/5 A; 30 VDC/4 A; 125 VAC/5 A; 250 VAC/5 A	
Minimum Load	5 VDC / 160 mA
Enclosure Rating	IP65 (DIN Connector 43650)
Materials in Contact with Fluid	
Body	Brass
Seals	NBR

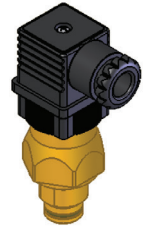

How to Order

Model Numbers

M699AG439851003

Electronic Liquid Level Indicator (for Lubricator)

Performance Data	
Actuation Point	25 ml (Nominal)
Switch Contact is open when fluid drops below 25 ml	
Connection	1/8-27 NPT External Thread
Electrical Ratings	
Switching Contact	SPST
Switch Type	50 Watt Reed Switch
Wire Size / Length	22 AWG / 610 mm
Materials in Contact with Fluid	
Body	Brass
Float	Nylon



How to Order

Model Numbers

M699AG506837001

01814GB-2016/R01
Availability, design and specifications are subject to change without notice. All rights reserved.

All leaflets are available on: www.asco.com

Repair Kits and Service Parts

651/652 Series - Spare Parts Kits

		Description	Series	Kit Number
Bowls*		Polycarbonate Bowl & Bowl Guard - Includes NBR Bowl Seal for Filters, Filter-Regulators and Lubricators (Electronic Liquid Level Indicator only)	651	M651AU434133001
			652	M652AU440511001
		Polycarbonate Bowl & Bowl Guard - Includes NBR Bowl Seal for Lubricators.	651	M651AU434133008
			652	M652AU440511008
		Metal bowl without sight gauge. Includes NBR Bowl Seal.	651	M651AU434133002
			652	M652AU440511002
		Metal bowl without sight gauge. Includes FKM Bowl Seal.	651	M651AU434133011
			652	M652AU440511011
		Metal bowl with borosilicate (glass) sight gauge. Includes NBR Bowl Seal.	651	M651AU434133004
			652	M652AU440511004
	Metal bowl with borosilicate (glass) sight gauge. Includes FKM Bowl Seal.	651	M651AU434133015	
		652	M652AU440511015	
Drains		Drain Plug Assembly. Provides an option to customers that do not want to use a bowl drain. Includes NBR seal.	651 652	M699AQ440512001
		Semi-Automatic/Manual Drain Assembly - with NBR seals. This normally open drain can be used as a manual drain or set to semi-automatic, which will drain the bowl upon a loss of system pressure. Drain material is plastic.	651 652	M699AQ440512002
		Semi-Automatic/Manual Drain Assembly - with FKM seals. This normally open drain can be used as a manual drain or set to semi-automatic, which will drain the bowl upon a loss of system pressure. Drain material is plastic.	651 652	M699AQ440512007
		Manual Stainless Steel Drain Assembly - with NBR seals. Provides the user with an alternative to the plastic semi-automatic drain.	651 652	M699AQ440512003
		Manual Stainless Steel Drain Assembly - with FKM seals. Provides the user with an alternative to the plastic semi-automatic drain.	651 652	M699AQ440512008
	Automatic Drain Assembly - with NBR seals. This drain uses a float that initiates the bowl to drain when the liquid rises. In addition, all fluid will drain when the pressure drops below 22 PSI. Drain material is brass. This drain can also be operated manually.	651 652	M699AQ501862001	
Bowl & Drain Assembly		Bowl and Drain Assembly - Includes Polycarbonate Bowl/Guard and Semi-Automatic Drain Assembly (NBR Seals).	651	M651AU514009001
			652	M652AU513311001

* For lubricator replacement metal bowls, please also order bowl plug p/n M699AQ440512001. This is not required if the Electronic Liquid Level Indicator is used.

Repair Kits and Service Parts
651/652 Series - Spare Parts Kits

		Description	Series	Kit Number	Color
Filter Elements		5 Micron Particulate Filter Element	651	M651AE434063001	White
			652	M652AE433582001	
		25 Micron Particulate Filter Element	651	M651AE434063002	Yellow
			652	M652AE433582002	
		0,3 Micron Coalescing Filter Element	651	EKF12D	Green
			652	EKF22D	
		0,01 Micron Coalescing Filter Element	651	EKF12E	Red
			652	EKF22E	
		0,3 Micron Coalescing Filter Element - with 3 Micron pre-filter	651	EKF12DD	Green
			652	EKF22DD	
		0,01 Micron Coalescing Filter Element - with 3 Micron pre-filter	651	EKF12ED	Red
			652	EKF22ED	
		Adsorber (Activated Carbon) Filter	651	EKF12F	Grey
			652	EKF22F	

01815GB-2016/R01
Availability, design and specifications are subject to change without notice. All rights reserved.

All leaflets are available on: www.asco.com



Repair Kits and Service Parts

651/652 Series - Air Prep Assembly and Mounting Kits

	Description	Series	Kit Number		
	Body-to-Body Assembly Clamps (Includes NBR O-Ring). Clamp material is aluminum.	651	P651AT504958001		
		652	P652AT502466001		
	Body-to-Body Assembly Clamps (Include FKM O-Ring). Clamp material is aluminum.	651	P651AT504958003		
		652	P652AT502466003		
	End Plate Kit: Includes two end plates and body-to-body assembly clamps & O-Ring. End plate material is aluminum.	NBR O-Ring	1/4 ISO228/1-G	651	T651AT504959002
			1/2 ISO228/1-G	652	T652AT502468002
		FKM O-Ring	1/4 ISO228/1-G	651	T651AT504959008
			1/2 ISO228/1-G	652	T652AT502468008
	Wall/Panel Bracket Kit includes one bracket and two screws for attaching bracket to body clamp. Two brackets are required for mounting three or more products. One bracket is suitable for mounting two products. Material is aluminum.	651 652	P699AT502467001		
	Side Mounting Brackets (Includes two brackets): Designed for mounting single products to wall or panel, but is capable of handling up to 3 stations. Material is stainless steel. Recommended only for static applications (without vibration).	651	P651AT503860001		
		652	P652AT503860002		
	Panel Nut: Used for Regulators and Filter-Regulators where adjustment knob is fed through a panel and the panel nut is then used to secure the product to the panel. Material is polyamide.	651	P651AT513928001		
		652	P652AT513177001		
	Panel Nut & Bracket: The panel nut and bracket are used to mount a Regulator or Filter-Regulator to a wall or panel. Materials are stainless steel and polyamide.	651	P651AT503861001		
		652	P652AT503861002		
	651 to 652 Series Transition Kit: Includes one 651 body clamp, one 652 body clamp, transition plate and required O-rings to transition from a 651 to a 652 Series component within a manifold configuration.	NBR O-Ring	651 652	T651AT519193001	
		FKM O-Ring	651 652	T651AT519193002	
	652 to 651 Series Transition Kit: Includes one 652 body clamp, one 651 body clamp, transition plate and required o-rings to transition from a 652 to a 651 Series component within a manifold configuration.	NBR O-Ring	651 652	T652AT519193003	
		FKM O-Ring	651 652	T652AT519193004	

01815GB-2016/R02
Availability, design and specifications are subject to change without notice. All rights reserved.

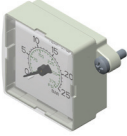
Repair Kits and Service Parts
651/652 Series - Spare Parts Kits

		Description	Series	Kit Number
No Gauge		No Gauge Cover Kit - NBR Seal. Includes gauge cover, screw and o-ring	651 652	M699AG503396001
		No Gauge Cover Kit - FPM Seal. Includes gauge cover, screw and o-ring	651 652	M699AG503396002
Integrated gauges*		Integrated Gauge - 651/652/653 Series: 0-6 bar Scale with NBR seals	651 652	M699AG438047002
		Integrated Gauge - 651/652/653 Series: 0-6 bar Scale with FPM seals	651 652	M699AG438047014
		Integrated Gauge - 651/652/653 Series: 0-12 bar Scale with NBR seals	651 652	M699AG438047001
		Integrated Gauge - 651/652/653 Series: 0-12 bar Scale with FPM seals	651 652	M699AG438047013
		Integrated Gauge - 653 Series and SOV: 0-25 bar Scale with NBR seals	651 652	M699AG438047003
		Integrated Gauge - 653 Series and SOV: 0-25 bar Scale with FPM seals	651 652	M699AG438047015
		Pressure Range Indicators (Red/Green) for low profile integrated gauges. Desired range can be easily set in the field. This kit allows customers to add the pressure range indicator to existing low profile integrated gauges in the field.	651 652	M699AG500179001
		Integrated Gauge with Pressure Range Indicators - 651/652/653 Series: 0-6 bar Scale with NBR seals	651 652	M699AG438047008
		Integrated Gauge with Pressure Range Indicators - 651/652/653 Series: 0-12 bar Scale with NBR seals	651 652	M699AG438047007
		Integrated Gauge with Pressure Range Indicators - 653 Series and Shut-off Isolation Valves: 0-25 bar Scale with NBR seals	651 652	M699AG438047009



t

01815GB-2016/R01
Availability, design and specifications are subject to change without notice. All rights reserved.

All leaflets are available on: www.asco.com

Repair Kits and Service Parts

651/652 Series - Spare Parts Kits

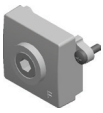
		Description	Series	Kit Number
Digital Gauge		Digital Pressure Gauge - 651/652/653 Series: 0-145 PSI Scale (User can change units; bar,MPa, Kg/cm ²) 1/8" ISO 7/1 Rc	651 652	M699AG504650002
Round Gauges*		Round Gauge - 0-4 bar 1/8 ISO 7/1 Rc and 40 mm Face Diameter	651	34300015
		Round Gauge - 0-10 bar 1/8 ISO 7/1 Rc and 40 mm Face Diameter	651	34300014
		Round Gauge - 0-12 bar 1/8 ISO 7/1 Rc and 40 mm Face Diameter	651	34300041
		Round Gauge - 0-25 bar 1/8 ISO 7/1 Rc and 50 mm Face Diameter	651 652	34200063
		Round Gauge - 0-4 bar 1/8 ISO 7/1 Rc and 50 mm Face Diameter	652	34200061
		Round Gauge - 0-12 bar 1/8 ISO 7/1 Rc and 50 mm Face Diameter	652	34200062
		Stainless Steel Round Gauge - 0-12 bar 1/8 ISO 7/1 Rc and 50 mm Face Diameter	651 652	34303242
Port Plates		Gauge Port Plate Assembly - 1/8 ISO 7/1 Rc	651 652	M699AG440510002
Pressure Switch/Sensor		DPS280 Pressure Switch/Sensor - NPN M8 with Cable 1/8 ISO 7/1 Rc	651 652	DPS280NRQ8
		DPS280 Pressure Switch/Sensor - PNP M8 with Cable 1/8 ISO 7/1 Rc	651 652	DPS280PRQ8

* Each of the Integrated and Round Gauges are dual scale. The scale that is listed in the description has the units located near the outside of the scale. The other units would be on the inside.

Note: For all pressure switches & round gauges that are added to the 652 series products in the field, a port plate is required. The port plate can be added at the time of order entry or as a kit.

Repair Kits and Service Parts
651/652 Series - Spare Parts Kits

		Description	Series	Kit Number
Lubricator Repair Kits		Lubricator dome repair kit - NBR seals. Includes dome cover, screw and o-rings.	651 652	M699AY506842001
		Lubricator dome repair kit - FKM seals. Includes dome cover, screw and o-rings.	651 652	M699AY506842002
		Lubricator Level Switch assembly kit. Includes level switch, stainless steel retainer ring, o-ring and bushing.	651 652	M699AG506837001
		Lubricator Bowl Plug assembly: Includes Lubricator bowl plug, stainless steel retainer ring and NBR o-ring.	651 652	M699AQ440512001
		Particulate Filter Repair Kit - Includes the filter retainer, head baffle, lower end cap and bowl baffle.	651	M651AY570170001
652			M652AY506833001	
Filter Kits		Differential Pressure Pop-Up Indicator (NBR Seals). This is used for the Coalescing Filters to provide visual indication when the filter element needs to be replaced.	651 652	M699AG439851001
		Differential Pressure Pop-Up Indicator (FKM Seals). This is used for the Coalescing Filters to provide visual indication when the filter element needs to be replaced.	651 652	M699AG439851004
		DPI Plug (NBR Seals). This is used to plug the top port on the filter when a Differential Pressure Indicator is not used.	651 652	M699AG439851002
			651 652	M699AG439851005
		Electric Differential Pressure Indicator (NBR Seals). This is used for the Coalescing Filter only. It provides a contact that will actuate when the filter element needs to be replaced.	651 652	M699AG439851003

01815GB-2016/R01
Availability, design and specifications are subject to change without notice. All rights reserved.

All leaflets are available on: www.asco.com

Repair Kits and Service Parts

651/652 Series - Spare Parts Kits

		Description	Series	Kit Number
Regulator & Filter Regulator Kits		Adjusting Screw Repair Kit - Includes adjusting screw, nut, washer and screw.	651	M651AY514012001
			652	M652AY506952001
		Key Lockable Adjusting Screw Repair Kit - Includes adjusting screw, adjusting nut, flat washer and screw.	651	M651AY514012002
			652	M652AY506952002
		Tamperproof Repair Kit - Includes adjusting screw, adjusting nut, flat washers and screws.	651	M651AY514012003
			652	M652AY506952003
		Replacement knob for regulator or filter-regulators.	651	M651AY519042001
			652	M652AY519042003
		Replacement knob for the tamper resistant or key lockable regulator or filter-regulators	651	M651AY519042002
			652	M652AY519042004
		Poppet Repair Kit (NBR Seals): Includes poppet, stem & seals.	651	M651AY507175001
			652	M652AY506863001
		Poppet Repair Kit (FKM Seals): Includes poppet, stem & seals.	651	M651AY507175002
			652	M652AY506863002
		Diaphragm Assembly Repair Kit (Pilot Operated Regulator NBR Seals).	652	M652AH435268001
		Diaphragm Assembly Repair Kit (Pilot Operated Regulator FKM Seals).	652	M652AH435268002
		Diaphragm Assembly Repair Kit (Relieving Regulator NBR Seals)	651	M651AH504954001
			652	M652AH434213001
Diaphragm Assembly Repair Kit (Relieving Regulator FKM Seals)		651	M651AH504954002	
		652	M652AH434213002	
	Diaphragm Assembly Repair Kit (Non-Relieving Regulator NBR Seals)	651	M651AH504954003	
		652	M652AH434213003	
	Diaphragm Assembly Repair Kit (Non-Relieving Regulator - FKM Seals)	651	M651AH504954004	
		652	M652AH434213004	
	Main Spring (3 bar)	651	M651AY514010001	
		652	M652AY513313001	
	Main Spring (10 bar)	651	M651AY514011001	
		652	M652AY513314001	
Bowl Seal Kits		U-Cup Seal Kit (NBR Seals). Kit contains 10 U-Cup seals. This seal is used for all 652 series bowls.	651	M651AH507403001
			652	M652AH507085001
		U-Cup Seal Kit (FKM Seals). Kit contains 10 U-Cup seals. This seal is used for all 652 series bowls.	651	M651AH507403002
			652	M652AH507085002

01815GE-2016/R01
Availability, design and specifications are subject to change without notice. All rights reserved.

Repair Kits and Service Parts
651/652 Series - Spare Parts Kits



		Description	Part/Kit Number 651/652
3/2 Slow Start - Quick Exhaust Valve Kits		Horizontal Solenoid Operator (190) - With Manual Override	19090017
		Horizontal Solenoid Operator (190) - Without Manual Override	19090005
		24 VDC coil with 4 Pin M12 Connection, for 190 Pilot Horizontal Solenoid Operator	43005525
		24 VDC coil with DIN Spade connection for 190 Pilot Horizontal Solenoid Operator	43004473
		120 VAC coil with DIN Spade connection for 190 Pilot Horizontal Solenoid Operator	43004471
		24 VAC coil with DIN Spade connection for 190 Pilot Horizontal Solenoid Operator	43004469
		240 VAC coil with DIN Spade connection for 190 Pilot Horizontal Solenoid Operator	43004472
		DIN Connector, without LED - 190 Pilot Horizontal Solenoid Operator	88122602
		DIN Connector, with LED, for 24 VAC/DC coil - 190 Pilot Horizontal Solenoid Operator	88122603
		DIN Connector, with LED, for 120 VAC coil - 190 Pilot Horizontal Solenoid Operator	88122605
	DIN Connector, with LED, for 240 VAC coil - 190 Pilot Horizontal Solenoid Operator	88122608	
		Vertical Solenoid Operator (189) - Without Manual Override	18990007
		24 VDC coil with 4 Pin M12 Connection, for 189 Pilot Vertical Solenoid Operator	43005523
		24 VDC coil with DIN Spade connection for 189 Pilot Vertical Solenoid Operator	43004166
		120 VAC coil with DIN Spade connection for 189 Pilot Vertical Solenoid Operator	43004419
		24 VAC coil with DIN Spade connection for 189 Pilot Vertical Solenoid Operator	43004416
		240 VAC coil with DIN Spade connection for 189 Pilot Vertical Solenoid Operator	43004422
		DIN Connector, without LED - 189 Pilot Vertical Solenoid Operator	88122404
		DIN Connector, with LED, for 24 VAC/DC coil - 189 Pilot Vertical Solenoid Operator	88122405
		DIN Connector, with LED, for 120 VAC coil - 189 Pilot Vertical Solenoid Operator	88122407
DIN Connector, with LED, for 240 VAC coil - 189 Pilot Vertical Solenoid Operator		88122410	
	Jumper Plate Kit: For Air Operated Internally Piloted 3/2 Slow Start-QE Valve	M699AY513316001	
	Pilot Port Plate: For Air Operated Externally Piloted 3/2 Slow Start-QE Valve, 1/8 ISO 7/1 Rc	M699AY513318001	
	Pilot Port Plate: For Air Operated Externally Piloted 3/2 Slow Start-QE Valve, 1/8 NPTF	M699AY513318002	

01815GB-2016/R01
Availability, design and specifications are subject to change without notice. All rights reserved.

All leaflets are available on: www.asco.com

Repair Kits and Service Parts

651/652 Series - Accessories

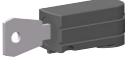
		Description	Series	Part Number
Scissor Lock		Scissor Lock for Shut-Off Isolation Valve & Lockout Valve	651 652	VB-1
Mufflers/Silencers		Metal Muffler – G 1/4 (Shut-Off Isolation Valves)	651 652	M2MB
		Metal Muffler – G 1/2 (Slow-Start/Quick Exhaust & Lockouts)	652	M4MB
		Polyethylene Muffler – G 1/4 (652 - Shut-Off Isolation Valve / 651 - Slow-Start/Quick Exhaust Valves)	651 652	34600407
		Polyethylene Muffler – G 1/2 (Slow-Start/Quick Exhaust & Lockouts)	652	34600409
Key Locking Device		Key Locking Device for regulator (Lock supplied separately with 2 keys)	651 652	M699AY438663001

OPTIONS

- Manual drain, code: **662563**
 - Additional by-pass insert for 4/6 tube, code: **685006**
 - Equipment for use in potentially explosive atmospheres caused by dusts or gases (ATEX Directive 2014/34/EU)
- | zones | classification | gas group | ATEX option code |
|-------|-------------------------|-------------|------------------|
| 2-22 | II 3GD c T85°C (T6) | IIA-IIB-IIC | 612077 |
| 1-21 | II 2GD c IIB T85°C (T6) | IIB | 612076 |

PRESSURE LOSS VERSUS AIR FLOW CURVE

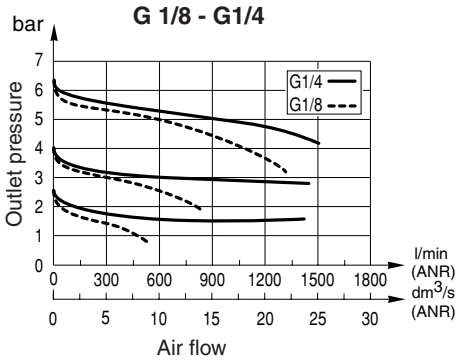

DIMENSIONS (mm), WEIGHT (kg)

Weight: 0,3

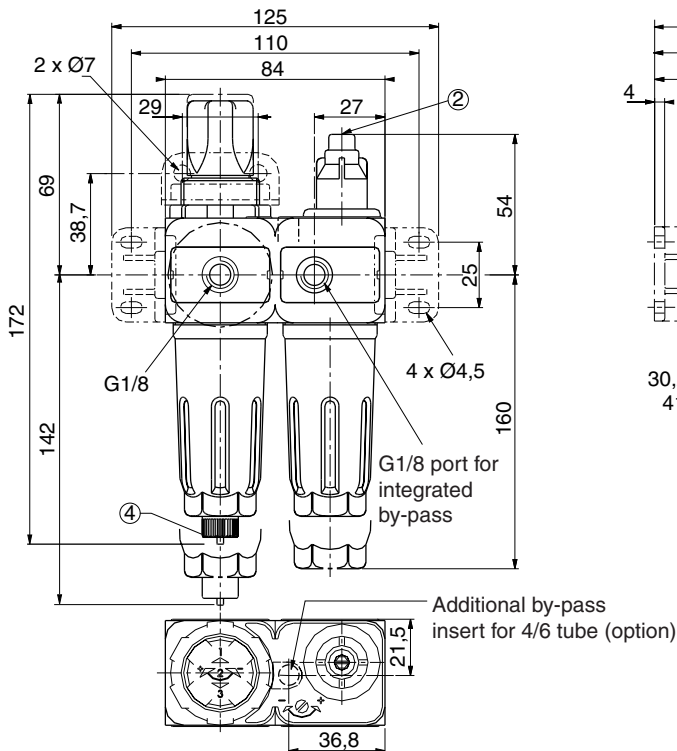

Mounting with side brackets

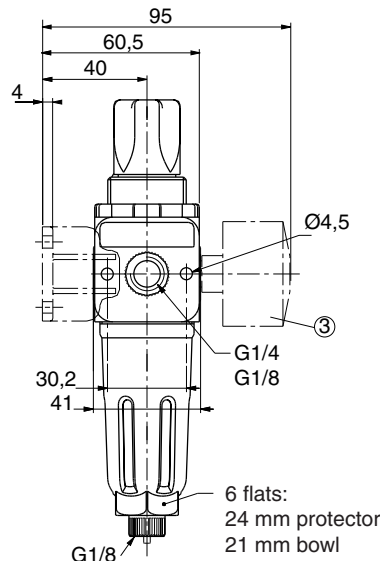

Mounting with upper bracket ①

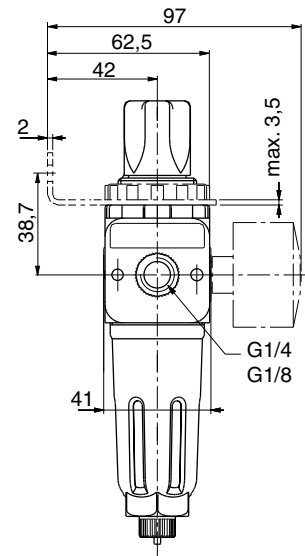

- ① Mounting by upper bracket (accessory) and mounting ring
- ② Oil flow adjustment screw

- ③ 40 mm dia. pressure gauge
- ④ Semi-automatic drain, connectable to G1/8 port

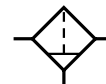

FEATURES

- Large choice of filtering capacities for oil and water aerosols: 5 and 25 microns
- Condensate level control with manual or semi-automatic integrated in the body
- Compatible for use in major industrial environments: polycarbonate bowl with protector

GENERAL

Fluid	Air or inert gas
Maximum inlet pressure (bar) P1 / at 23°C	12
/ at 50°C	10
Ambient temperature range (°C)	+0 to +50
Max. flow (Qv at 6,3 bar)	See table below and chart

CONSTRUCTION

Filtering capacity	25 µm and 5 µm
Filter element	Sintered polyethylene
Body	PA (polyamide), glass-fibre reinforced
Bowl	Polycarbonate bowl (PC), UV resistant
Condensate drain	Semi-automatic (operating pressure: min. 1,2 bar) or manual (as option)



SPECIFICATIONS

pipe size	bowl capacity		flow (ANR)		catalogue number	
			at 6,3 bar ΔP = 1 bar 25 µm ⁽¹⁾		semi-automatic drain	
	total (cm ³)	useful (cm ³)	max.		25 µm	5 µm
(G)			l/min	l/min		
Polycarbonate bowl WITH protector ⁽¹⁾						
1/8	28	10	890	14,8	34225213	34225253
1/4	28	10	1050	17,5	34225214	34225254
Polycarbonate bowl WITHOUT protector						
1/8	28	10	890	14,8	34225133	34225173
1/4	28	10	1050	17,5	34225134	34225174

⁽¹⁾ With a 5 µm filtering element flow is reduced by approx. 15%.

INSTALLATION

- Systems must be installed with the bowls in vertical position (at the bottom)
- Air flow direction indicated by arrow and "IN" - "OUT" marking on body
- Use an alkaline solution (soapy water) and not a solvent for cleaning the polycarbonate bowls and sight glasses

ACCESSORIES (See Accessories pages)

00752GB-2016/R01 Availability, design and specifications are subject to change without notice. All rights reserved.

All leaflets are available on: www.asco.com

OPTIONS

- Manual drain, code: **662563**
- Equipment for use in potentially explosive atmospheres caused by dusts or gases (ATEX Directive 2014/34/EU)

zones	classification	gas group	ATEX option code
2-22	II 3GD c T85°C (T6)	IIA-IIIB-IIIC	612077
1-21	II 2GD c IIB T85°C (T6)	IIB	612076

PRESSURE LOSS VERSUS AIR FLOW CURVES

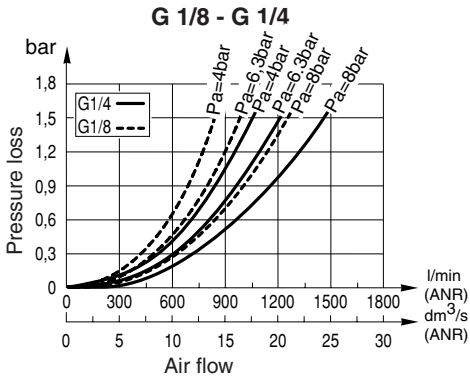

DIMENSIONS (mm), WEIGHT (kg)

Weight: 0,134

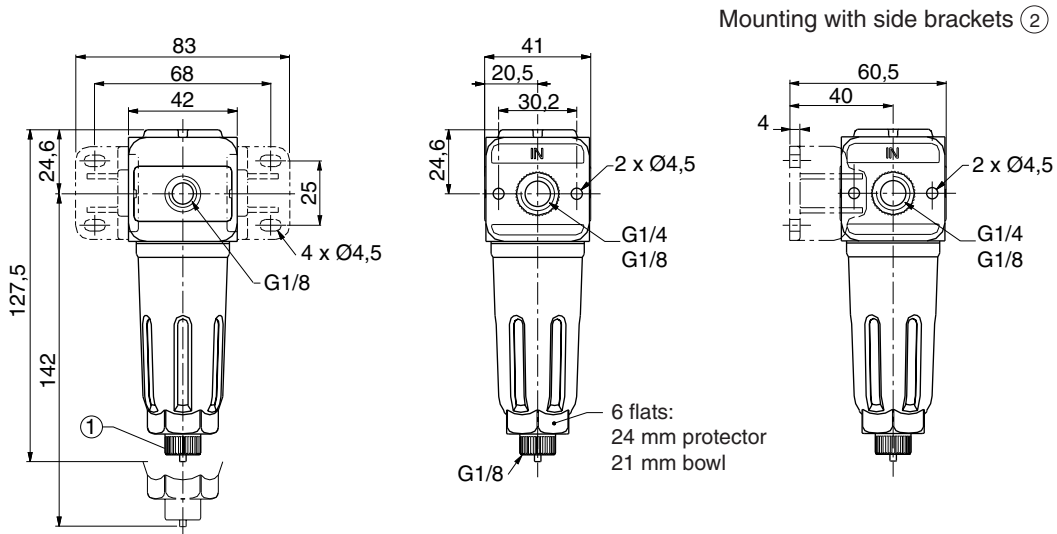

- ① Semi-automatic drain, connectable to G1/8 port
- ② Mounting by side brackets (accessory)

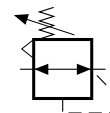

FEATURES

- Wide selection of pressure regulation ranges: from between 0,2 and 0,5 bar to 3 or 8 bar
- Ensures constant downstream pressure: rolling diaphragm, self-relieving feature
- Reliability and durability: low hysteresis, rolling diaphragm, no friction

GENERAL

Fluid	Air or inert gas
Maximum inlet pressure (bar) P1 / at 23°C	12
Adjustable pressure ranges (bar) P2	0,2 to 3 / 0,5 to 8
Hysteresis (bar)	0,35
Ambient temperature range (°C)	+0 to +50
Max. flow (Qv at 6,3 bar)	See table below and chart
Regulator	Self-relieving



CONSTRUCTION

Seals	NBR (nitrile)
Body	PA (polyamide), glass-fibre reinforced
Pressure control knob	Locking "pull-turn-push"
Regulating device	With rolling diaphragm (very low hysteresis)

SPECIFICATIONS

pipe size	inlet pressure P1		adjustable pressure range	flow			gauge diameter	catalogue number	
	max.			inlet pressure P1	Setpoint P2 = 6,3 bar ΔP = 1 bar			with 0-10 bar gauge	without gauge
(G)	(cm ³)	(bar)	(bar)	l/min (ANR)	dm ³ /s (ANR)				
Adjustment range: STANDARD									
1/8	12	0,5 to 8	8	550	9	40	34225007	34225005	
1/4	12	0,5 to 8	8	650	11	40	34225008	34225006	
Adjustment range: LOW									
with 0-4 bar gauge									
1/8	12	0,2 to 3	8	550	9	40	34225261	34225259	
1/4	12	0,2 to 3	8	650	11	40	34225262	34225260	

⁽¹⁾ Other adjustment ranges on request.

INSTALLATION

- Regulators can be installed in any position
- Panel mounting possible (mounting ring)
- Air flow direction indicated by arrow and "IN" - "OUT" marking on body

ACCESSORIES (See Accessories pages)

00753GB-2016/R01
Availability, design and specifications are subject to change without notice. All rights reserved.

All leaflets are available on: www.asco.com

OPTIONS

• Equipment for use in potentially explosive atmospheres caused by dusts or gases (ATEX Directive 2014/34/EU)			
zones	classification	gas group	ATEX option code
2-22	II 3GD c T85°C (T6)	IIA-IIB-IIC	612077
1-21	II 2GD c IIC T85°C (T6)	IIC	612066

PRESSURE LOSS VERSUS AIR FLOW CURVES

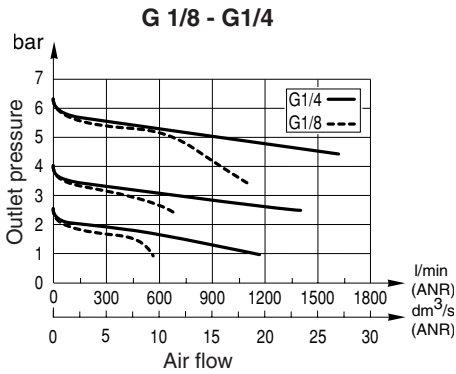

DIMENSIONS (mm), WEIGHT (kg)

Weight: 0,135

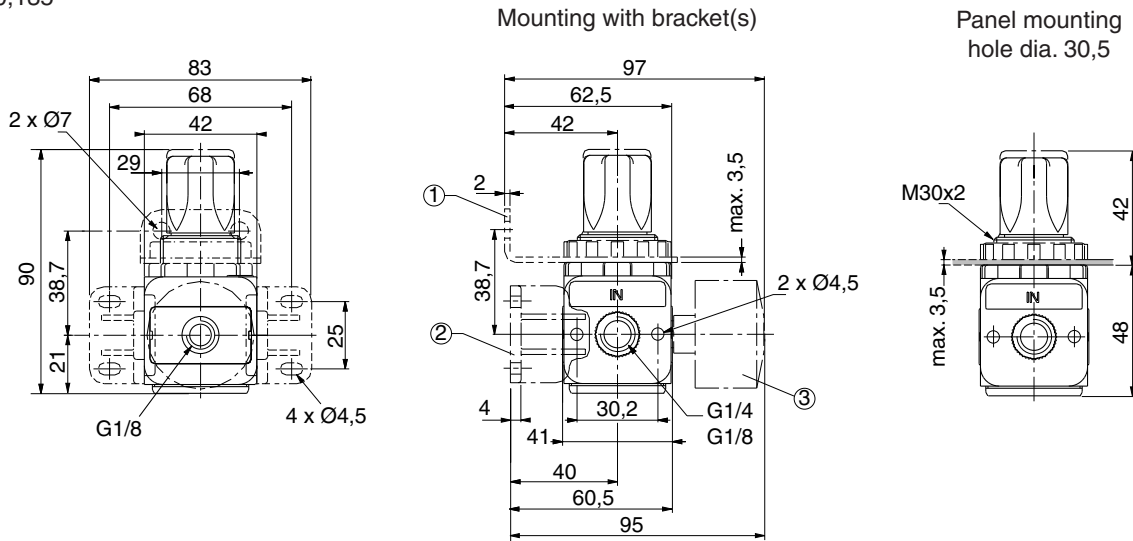

- ① Mounting with top bracket (accessory) and mounting ring
- ② Mounting with 2 side brackets (accessory)
- ③ 40 mm dia. pressure gauge

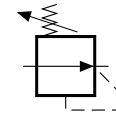

FEATURES

- Wide tap water pressure regulation ranges: 0,3-0,5 to 3-6 bar
- Reliability and durability, low hysteresis, rolling diaphragm, no friction
- Non-self-relieving regulator

GENERAL

Fluid	Water
Maximum inlet pressure (bar) P1	12
Adjustable pressure ranges (bar) P2	0,2 to 3 / 0,5 to 6
Hysteresis (bar)	0,35
Ambient temperature range (°C)	+5 to +50
Max. flow (Qv at 6,3 bar)	550 l/min - 650 l/min

CONSTRUCTION

Seals	NBR (nitrile)
Body	PA (polyamide), glass-fibre reinforced
Pressure control knob	Locking "pull-turn-push"



SPECIFICATIONS

pipe size	inlet pressure P1	adjustable pressure range	flow coefficient Kv		gauge diameter	catalogue number	
	max.		(m³/h)	(l/min)		with 0-10 bar gauge	without gauge
(G)	(cm³)	(bar)					
Adjustment range: STANDARD							
1/8	12	0,5 to 6	0,58	9,7	40	34225273	34225271
1/4	12	0,5 to 6	0,90	15	40	34225274	34225272
Adjustment range: LOW							
						with 0-4 bar gauge	
1/8	12	0,2 to 3	0,90	9,7	40	34225269	34225267
1/4	12	0,2 to 3	0,58	15	40	34225270	34225268

INSTALLATION

- Regulators can be installed in any position
- Panel mounting possible (mounting ring)
- Air flow direction indicated by arrow and "IN" - "OUT" marking on body

ACCESSORIES (See Accessories pages)

OPTIONS

- Equipment for use in potentially explosive atmospheres caused by dusts or gases (ATEX Directive 2014/34/EU)

zones	classification	gas group	ATEX option code
2-22	II 3GD c T85°C (T6)	IIA-IIIB-IIC	612077
1-21	II 2GD c IIC T85°C (T6)	IIC	612066

DIMENSIONS (mm), WEIGHT (kg) 
Weight: 0,130

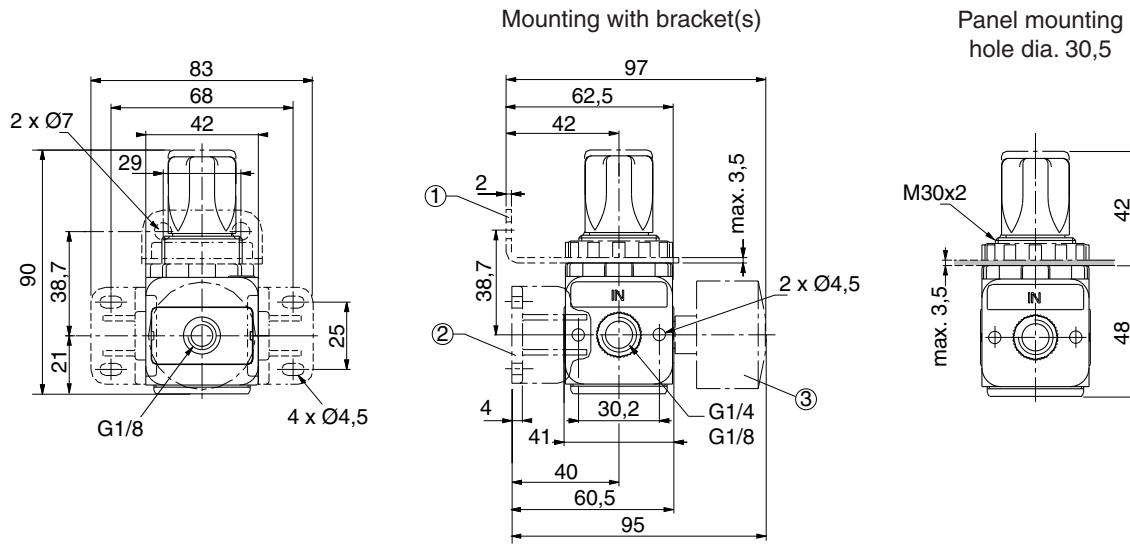

- ① Mounting with top bracket (accessory) and ring
- ② Mounting with 2 side brackets (accessory)
- ③ 40 mm dia. pressure gauge

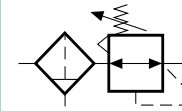

FEATURES

- Quick installation and connection to systems: filter and regulator functions in a "single unit"
- Light weight and robust design for installation on piping systems

GENERAL

Fluid	Air or inert gas
Maximum inlet pressure (bar) P1 / at 23°C	12
/ at 50°C	10
Adjustable pressure ranges (bar) P2	0,5 to 8
Hysteresis (bar)	0,35
Ambient temperature range (°C)	+0 to +50
Max. flow (Qv at 6,3 bar)	See table below and chart
Regulator	Self-relieving



CONSTRUCTION

Filtering capacity	25 µm (5 µm on request)
Semi-automatic drain	Operating pressure: min. 1,2 bar
Pressure control knob	Locking "pull-turn-push"
Regulating device	With rolling diaphragm (very low hysteresis)

SPECIFICATIONS

pipe size	bowl capacity	adjustable pressure range	flow			gauge diameter	catalogue number	
			inlet pressure P1	Setpoint P2 = 6,3 bar ΔP = 1 bar			semi-automatic drain	
				l/min (ANR)	dm³/s (ANR)		with 0-10 bar gauge	without gauge
(G)	(cm³)	(bar)	(bar)					
25 µm - Polycarbonate bowl WITH protector ⁽¹⁾								
1/8	28	0,5 to 8	8	550	9	40	34225203	34225201
1/4	28	0,5 to 8	8	650	11	40	34225204	34225202
25 µm - Polycarbonate bowl WITHOUT protector								
1/8	28	0,5 to 8	8	550	9	40	34225123	34225121
1/4	28	0,5 to 8	8	650	11	40	34225124	34225122

⁽¹⁾ Adjustment range 0,2 to 3 bar and other values on request.

INSTALLATION

- Systems must be installed with the bowls in vertical position (at the bottom)
- Air flow direction indicated by arrow and "IN" - "OUT" marking on body
- Use an alkaline solution (soapy water) and not a solvent for cleaning the polycarbonate bowls and sight glasses

ACCESSORIES (See Accessories pages)

OPTIONS

- Manual drain, code: **662563**
- Equipment for use in potentially explosive atmospheres caused by dusts or gases (ATEX Directive 2014/34/EU)

zones	classification	gas group	ATEX option code
2-22	II 3GD c T85°C (T6)	IIA-IIB-IIC	612077
1-21	II 2GD c IIB T85°C (T6)	IIB	612076

PRESSURE LOSS VERSUS AIR FLOW CURVE

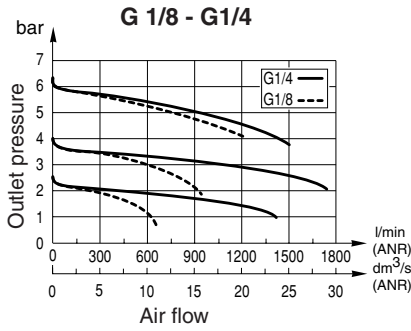

DIMENSIONS (mm), WEIGHT (kg)

Weight: 0,190

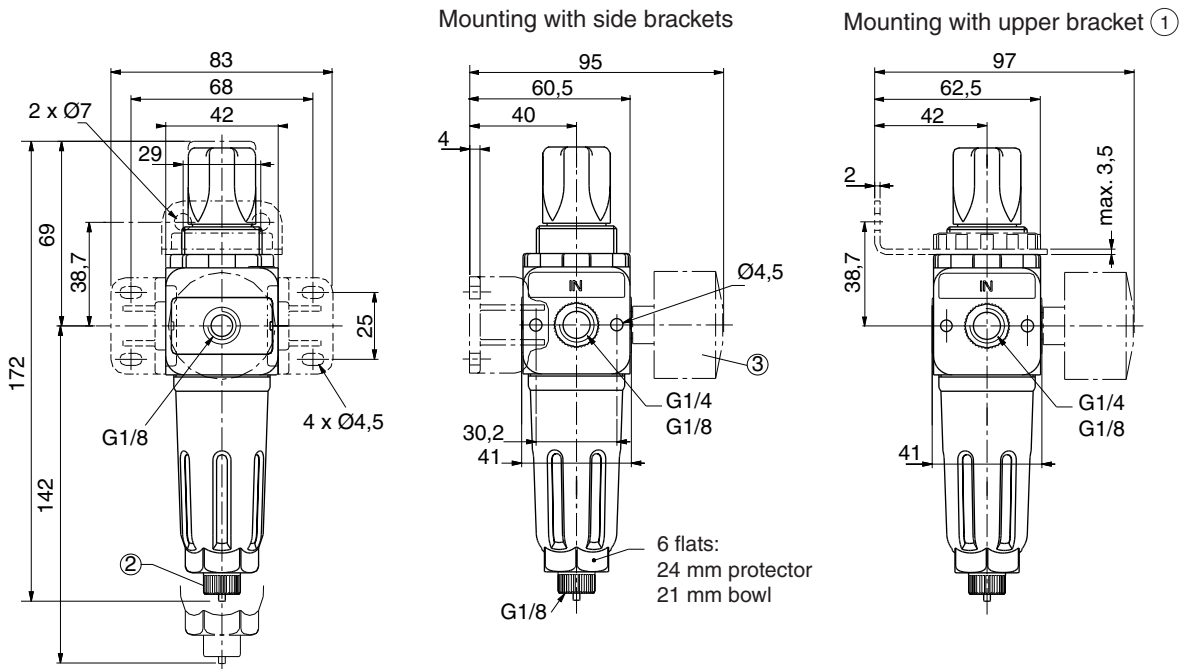

- ① Mounting with top bracket (accessory) and mounting ring
- ② Semi-automatic drain, connectable to G1/8 port

- ③ 40 mm dia. pressure gauge

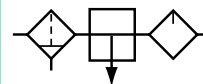

FEATURES

- Constant and controlled filtration and lubrication over a central regulating system
- Compact component for secondary pneumatic circuits
- Light weight and robust design for installation on piping systems

GENERAL

Fluid	Air or inert gas
Maximum inlet pressure (bar) P1	10
Ambient temperature range (°C)	+0 to +50
Max. flow (Qv at 6,3 bar)	See table below and chart
Min. start point	See table below
Lubrication	Selective oil fog

CONSTRUCTION

Filtering capacity	25 µm (5 µm on request)
Filter element	Sintered polyethylene
Body	PA (polyamide), glass-fibre reinforced
Bowl	Polycarbonate bowl (PC), UV resistant
Semi-automatic drain	Operating pressure: min. 1,2 bar
Lubricator	Oil refilling unpressurised; screw adjustment
By-pass module	Integrated



SPECIFICATIONS

pipe size	bowl capacity		max. oil capacity	filtering capacity	flow (ANR)				catalogue number
	total	useful			min. ⁽¹⁾		max.		
(G)	(cm ³)	(cm ³)	(cm ³)	(µm)	(l/min)	(dm ³ /s)	(l/min)	(dm ³ /s)	semi-automatic drain
Polycarbonate bowl WITH protector									
1/8	28	10	23	25	20	0,3	830	13,8	34225193
1/4	28	10	23	25	20	0,3	950	15,8	34225194
Polycarbonate bowl WITHOUT protector									
1/8	28	10	23	25	20	0,3	830	13,8	34225113
1/4	28	10	23	25	20	0,3	950	15,8	34225114

⁽¹⁾ Minimum for lubricator startup.

INSTALLATION

- Systems must be installed with the bowls in vertical position (at the bottom)
- Air flow direction indicated by arrow and "IN" - "OUT" marking on body
- Recommended type of oil: non-detergent and without aggressive additives, viscosity VG32 (ISO 3448)
- Use an alkaline solution (soapy water) and not a solvent for cleaning the polycarbonate bowls and sight glasses

ACCESSORIES AND OPTIONS

- Side mounting brackets, code: **34325005**
 - Manual drain, code: **662563**
 - Additional by-pass insert for 4/6 tube, code: **685006**
 - Equipment for use in potentially explosive atmospheres caused by dusts or gases (ATEX Directive 2014/34/EU)
- | zones | classification | gas group | ATEX option code |
|-------|-------------------------|-------------|------------------|
| 2-22 | II 3GD c T85°C (T6) | IIA-IIB-IIC | 612077 |
| 1-21 | II 2GD c IIB T85°C (T6) | IIB | 612076 |

PRESSURE LOSS VERSUS AIR FLOW CURVES

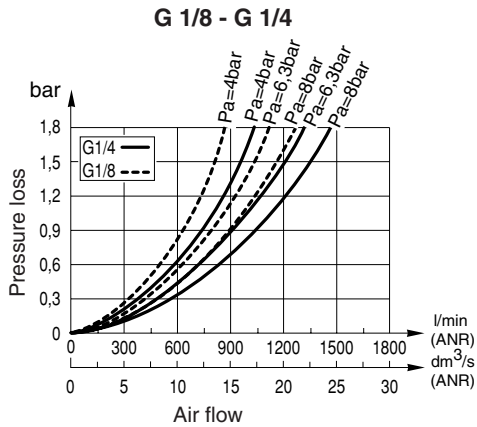

DIMENSIONS (mm), WEIGHT (kg)

Weight: 0,240

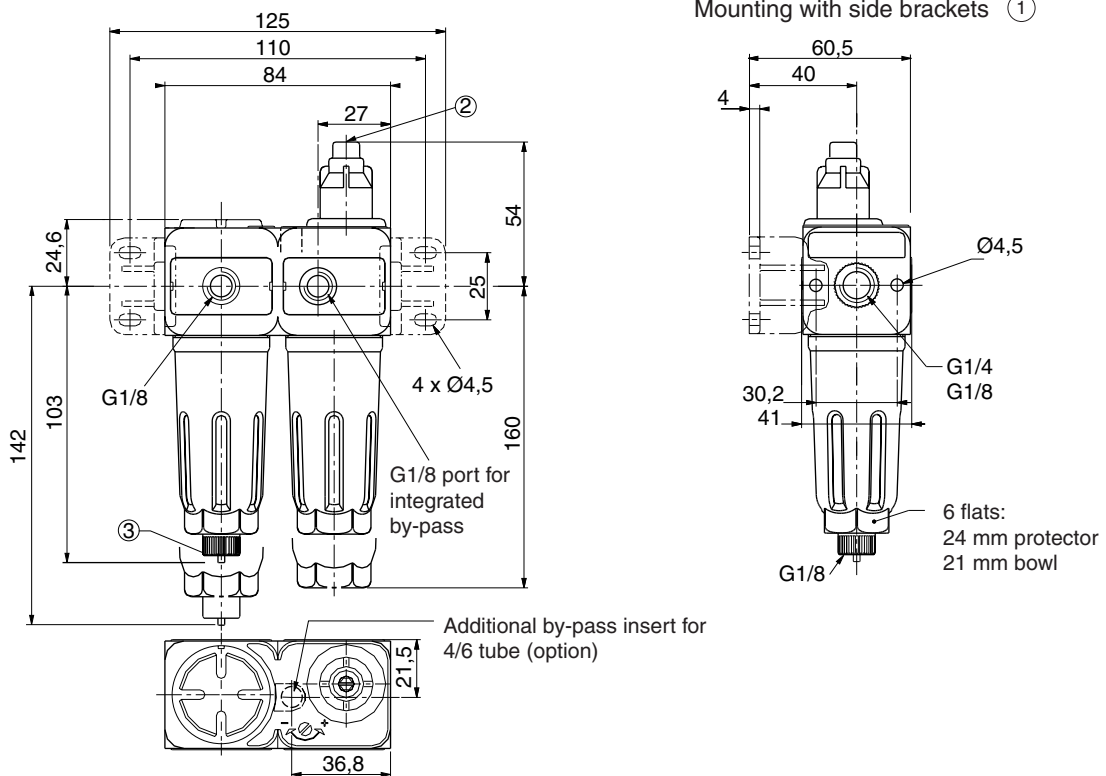

- ① Mounting by side brackets (accessory)
- ② Oil flow adjustment screw
- ③ Semi-automatic drain, connectable to G1/8 port

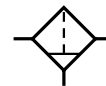

SIDE MOUNTING BRACKETS

FEATURES

- Side mounting brackets are for surface mounting of the Modulair 105 components

CONSTRUCTION

Brackets

Glass-fibre reinforced polyamide 6/6

Retaining screw

Steel

SPECIFICATIONS

description	catalogue number
1 set of 2 side mounting brackets	34325005



TOP MOUNTING RING AND BRACKET

FEATURES

- The top mounting ring and bracket fit the filter/regulator and regulator. These accessories enable bulkhead-mounting of the components
- The mounting ring can be used separately for panel mounting of a regulator

CONSTRUCTION

Panel Nut

Light alloy

Panel Bracket

Black-finish zinc-plated steel

SPECIFICATIONS

description	catalogue number
Panel Nut	34300011
Panel Bracket	34300016



DIMENSIONS (mm)

SIDE MOUNTING BRACKETS

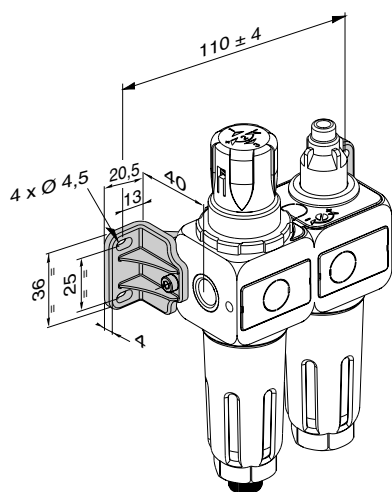

TOP MOUNTING RING AND BRACKET

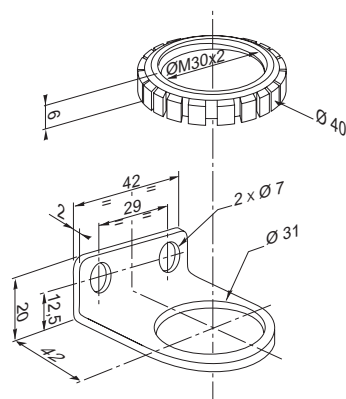

ROUND GAUGES

FEATURES

- Fits of regulator and filters/regulator

CONSTRUCTION

Fluid Filtered air or neutral gas, lubricated or NOT
Scale range bar and psi

SPECIFICATIONS

description	catalogue number
0-4 bar 1/8 ISO 7/1 Rc and 40 mm Face Diameter	34300015
0-10 bar 1/8 ISO 7/1 Rc and 40 mm Face Diameter	34300014



LOCK FOR PRESSURE ADJUSTMENT KNOB FOR REGULATOR AND FILTER/REGULATOR

FEATURES

- These accessories is used to lock the adjustment knob to prevent inadvertent adjustment of operating pressure. It can be fitted to regulator and filter/regulator whether they are combined with other components or not

CONSTRUCTION



Lock device:
With key Plastic
Ring and screw Acetal resin
With screw Steel
Plug-type Plastic



SPECIFICATIONS

It is possible to order:

- product equipped with this device
- product intended for use with this device
- the lock device separately

description	Lock device			
	With key	with ring and screw	With screw	with plug (pre-set pressure)
Lock device supplied with regulator or filter/regulator ⁽¹⁾				
Lock device, supplied separately	662574	662582	662584	662583
Preparation of regulator or filter/regulator designed to subsequently receive the lock device ⁽¹⁾	662575	662575	662586	-
	34303050 ⁽²⁾	34304025	34303173	-

⁽¹⁾ This option code is added to the standard code of the regulator, filter/regulator or system.

⁽²⁾ Lock supplied separately with 2 keys (weight: 0.060 kg)

DIMENSIONS (mm), WEIGHT (kg)

ROUND GAUGES
Weight: 0,065

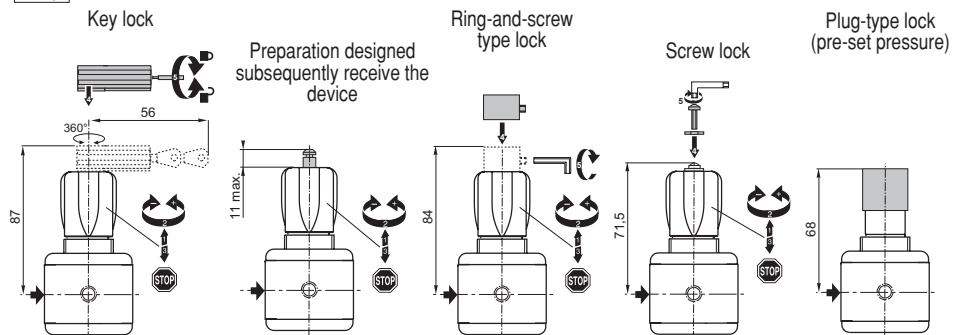
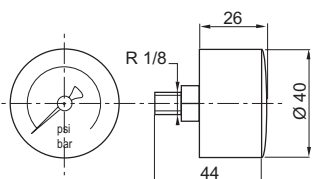

All leaflets are available on: www.asco.com



SPECIFICATION

FLUID CONTROLLED	: Filtered compressed air, neutral gases and water
PORTS	: G 1/8 - G 1/4
MAX. INLET PRESSURE	: 12 bar
ADJUSTMENT RANGES	: 0,2 - 3 bar, 0,5 - 10 bar (0,3 - 6 bar / water)
AMBIENT TEMPERATURE	: -10°C to +60°C
MAX. FLOW (Qv at 6 bar)	: 500 l/min - 650 l/min (ANR)
HYSTERESIS	: 0,350 bar
SELF-RELIEVING REGULATOR (for air or neutral gases)	
WITHOUT SELF-RELIEVING REGULATOR (for water)	

CONSTRUCTION

- Rolling membrane regulation device (very low hysteresis)
- Core and seals of nitrile (NBR)
- Body and bonnet of glass fibre reinforced polyamide (PA + FG)
- Pressure control button with "pull-turn-push" locking system
- Flow direction indicated by arrow
- Two G 1/8 ports provided for a pressure gauge on the regulator (+ 1 blanking plug)
- Miniature regulator mounting options:
 - direct mounting with two 4 mm dia. screws through the 40 mm long holes in the body (screws not supplied)
 - panel mounting (30,5 mm dia.) using the mounting ring supplied with each regulator
 - mounting by bracket at top (accessory)



CHOICE OF EQUIPMENT

Air or neutral gases version				
Port size	Maximum flow at 6,3 bar at setpoint pressure and ΔP of 1 bar / setpoint		CODES	
	l/min (ANR)	dm ³ /s (ANR)	Adjustment range	
			0,2 - 3 bar	0,5 - 10 bar
G 1/8	500	8,5	34200312	34200311
G 1/4	650	11	34200314	34200313

Water version				
Port size	Flow coefficient Kv		CODES	
	m ³ /h	l/min	Adjustment range	
			0,2 - 3 bar	0,3 - 6 bar
G 1/8	0,37	6,2	34202048	34202050
G 1/4	0,46	7,6	34202049	34202051

PRESSURE LOSS VERSUS AIR FLOW CURVES

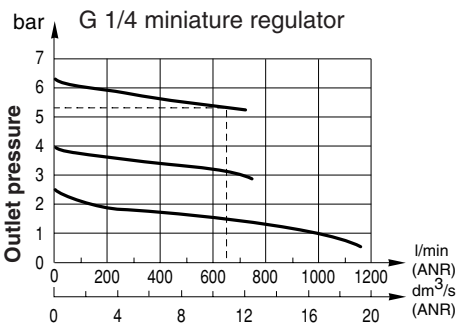
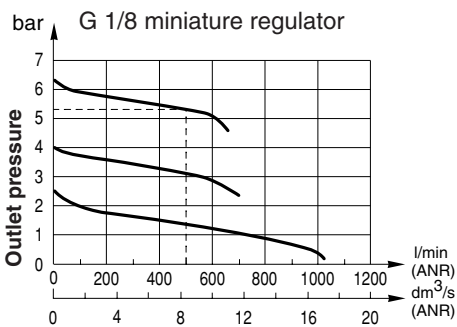

ACCESSORIES (valid for air or water)

- 40 mm dia. pressure gauge: 0-4 bar code: **34300015**
0-12 bar code: **34300041**
- Top mounting bracket: code: **34300016**

DIMENSIONS AND WEIGHTS

Weights G 1/8: 118 g
G 1/4: 108 g

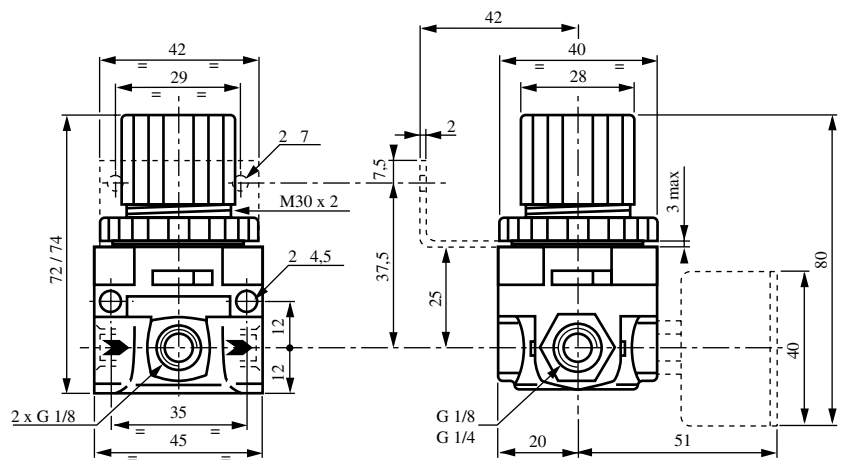

00714GB-2016/R01
Availability, design and specifications are subject to change without notice. All rights reserved.

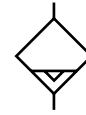

GENERAL

The automatic drain valve collects and drains, by means of a built-in automatic valve, water within compressed air systems. For a longer lifetime of the automatic drain valve, the unit includes a 55µm filter element to strain main condensates.

MOUNTING

The auto drain valve must be fitted vertically, at the lowest point of the air system

SPECIFICATIONS

FLUID : Compressed air
 CONNECTION : G 1/2
 MAX. PRESSURE : 16 bar at 50°C
 PRESSURE RANGE : 1 to 16 bar



CONSTRUCTION

Body : aluminium
 Automatic drain valve : POM, nitrile, aluminium, stainless steel
 Filter element (55µm) : polyester and stainless steel
 Bowl : polycarbonate - **For maintenance : never use a solvent. Use an alkaline solution** (soapy water)

CHOICE OF EQUIPMENT

Ø connection	Pressure range	CODE
G 1/2	1 - 16 bar	34201471

SPARE PARTS

55 µm filter element for automatic drain valve - code : **97801528**

To remove the filter element, first close the air inlet then press the unlocking button (the bowl is automatically vented to atmosphere) and unscrew the bowl 1/4 a turn to open it.

DIMENSIONS AND WEIGHT

Weight : 0,570 Kg

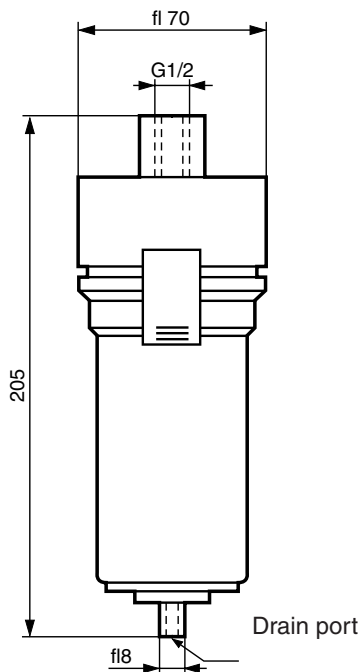

MOUNTING

(at the lowest point of the air system)

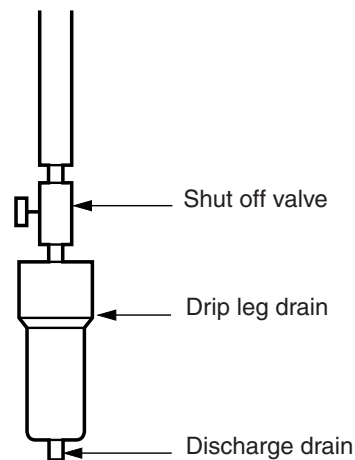

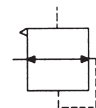

FEATURES

- Pilot Operated Regulators are adapted for control by a remote or distant small pilot regulator
- Ideal for maximum capacity requirements in applications where standard models would not be readily accessible
- High Flow
- Relieving or non-relieving models

SPECIFICATION

FLUID	: Compressed air or neutral gas, filtered
PORTS	: G1/4 to G 2 1/2
MIN. PILOT PRESSURE	: 0,5 bar
MAX. PILOT PRESSURE	: 20 bar
MAX. SUPPLY PRESSURE	: 20 bar
MAX. FLOW	: See curves next page
OPERATING TEMPERATURE	: +5°C to +50°C
REGULATOR	: Relieving or non-relieving

CONSTRUCTION

Regulating device with diaphragm
Reduced pressure within 0,35 to 0,5 bar of pilot pressure
All regulators have R threads for the gauges

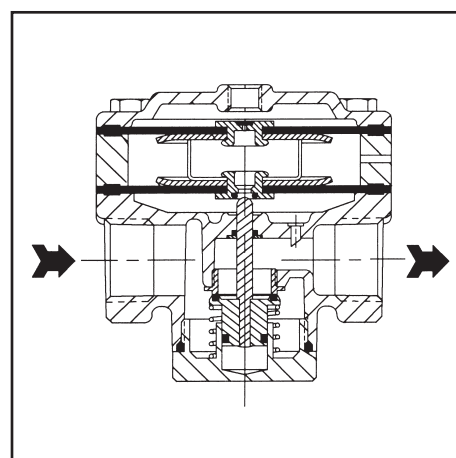

CHOICE OF EQUIPMENT

port size	pilot air port size	flow* l/min ANR at			pilot pressure		maximum supply pressure	Catalogue number	Options	
		2 bar	4 bar	6 bar	min	max			with gauge**	non-relieving
G	G									
1/4	1/8	1855	3090	3090	0,5	20	20	R50WG02	G	N
3/8	1/8	3400	4360	3705	0,5	20	20	R50WG03	G	N
1/2	1/4	4945	5870	6180	0,5	20	20	R50WG04	G	N
3/4	1/4	11430	11895	12205	0,5	20	20	R50WG06	G	N
1	1/4	11430	11895	12205	0,5	20	20	R50WG08	G	N
1 1/4	1/4	11430	11895	12205	0,5	20	20	R50WG10	G	N
1 1/2	1/4	11430	11895	12205	0,5	20	20	R50WG12	G	N
2	1/4	33985	38620	41710	0,5	20	20	R50WG16	G	-
2 1/2	1/4	33985	38620	41710	0,5	20	20	R50WG20	G	-

* Flow rate at 7 bar input pressure and 25% Δp

** R thread

Order example: **R50WG10N**

This is a non-relieving High Flow 50 Series Pilot Operated Regulator. Port size is G 1 1/4.

00628B-2017/R01 Availability, design and specifications are subject to change without notice. All rights reserved.

All leaflets are available on: www.asco.com

Flow Rates based on 7 bar inlet

50 Series Pilot Operated Regulator (02,03,04)

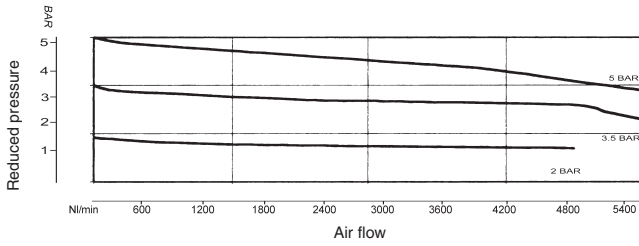

50 Series Pilot Operated Regulator (02,03,04)

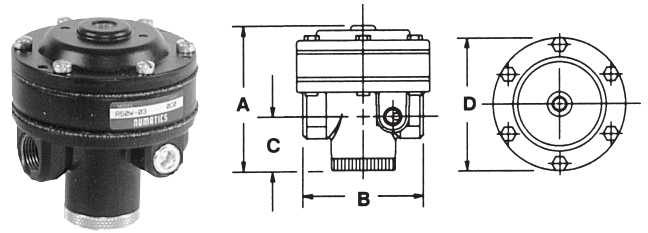

50 Series Pilot Operated Regulator (06,08)

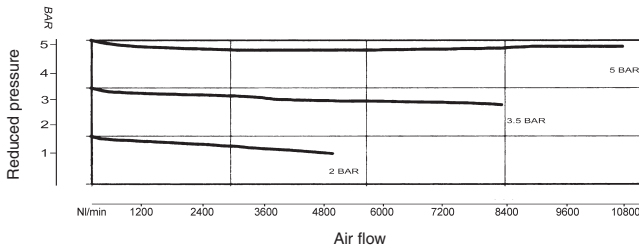

50 Series Pilot Operated Regulator (06,08)

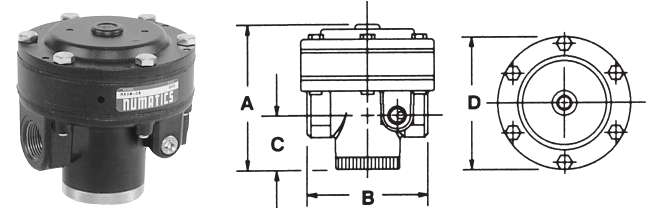

50 Series Pilot Operated Regulator (10,12)

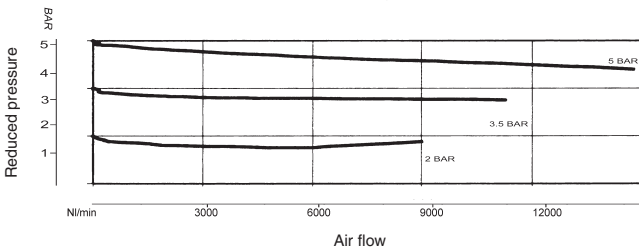

50 Series Pilot Operated Regulator (10,12)

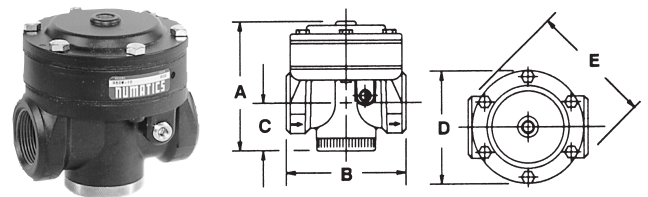

50 Series Pilot Operated Regulator (16,20)

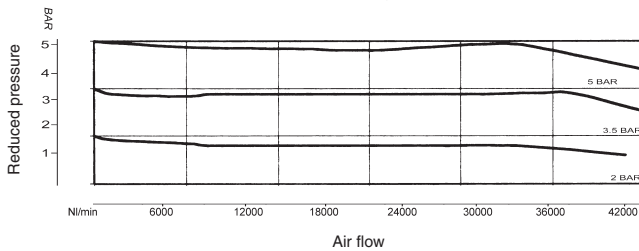

50 Series Pilot Operated Regulator (16,20)

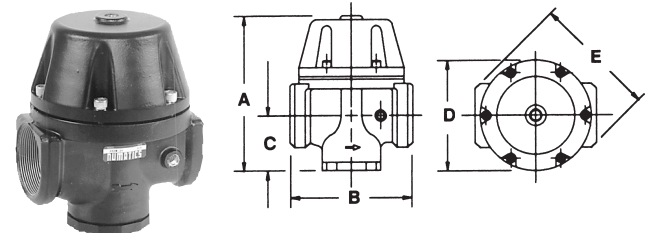

Dimensions [mm]

Order Code	A	B	C	D	E	Weight [kg]
R50WG02 R50WG03	86,0	70,0	35,0	76,0	—	0,7
R50WG04	98,5	82,5	37,5	90,5	—	1,1
R50WG06 R50WG08	123,0	113,0	49,0	119,0	—	2,4
R50WG10 R50WG12	132,0	125,0	48,0	119,0	141,0	2,5
R50WG16 R50WG20	225,5	185,5	78,5	168,5	203,0	6,8

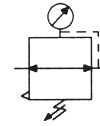

FEATURE

- High precision and multi-stage pressure regulators
- Standard version R80, high relief version R82 and high flow version R88

GENERAL / OPERATING PRINCIPLE

For R80-R82 series, the highest degree of regulation are achievable by reacting to downstream pressure fluctuations as small as 0,7 mbar. Action occurs as downstream pressure is piloted to the control chamber to act on a finely tuned stainless steel volume capsule.

A continuous bleed adjusts the pilot diaphragm causing appropriate movement of the valve.

The R88 Series pressure control regulator is designed for high flow and accurate pressure control utilizing a rolling diaphragm to insure a constant output pressure

SPECIFICATIONS

	R80 - R82	R88
Flow rate (ANR)	460 l/min	1800 l/min (courbes p 2)
Relief capacity	R80 = 62 l/min ANR R82 = 305 l/min ANR	120 l/min ANR
Sensitivity	3 mbar	0,6 mbar
Pilot bleed rate	2,5 l/min	0,55 à 6,5 l/min
Maximum supply pressure	10 bar	17 bar
Filtered air	25 µm	25 µm
Max.oil concentration in air	1 mg/cm ³	

CONSTRUCTION

Body	Die cast zinc
Diaphragms	NBR
Knob	Phanolic plastic

CHOICE OF EQUIPMENT

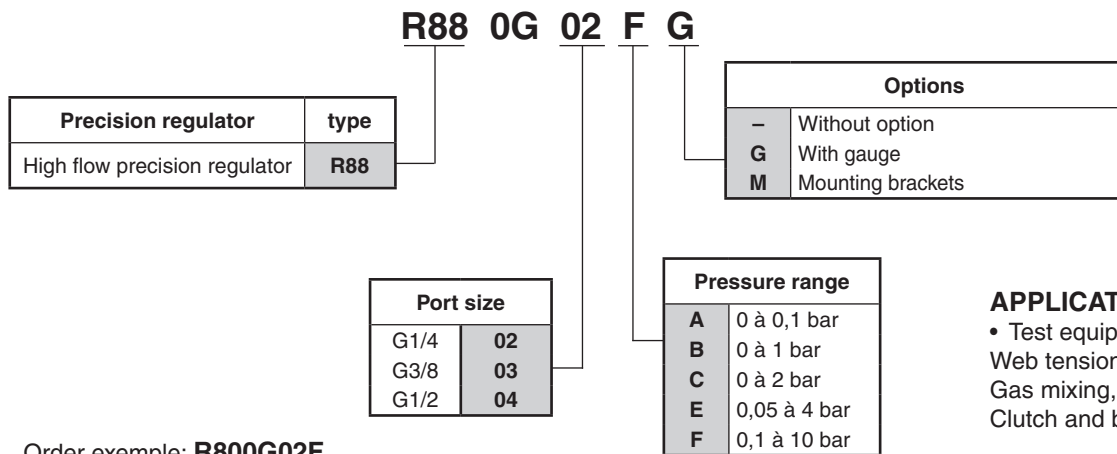
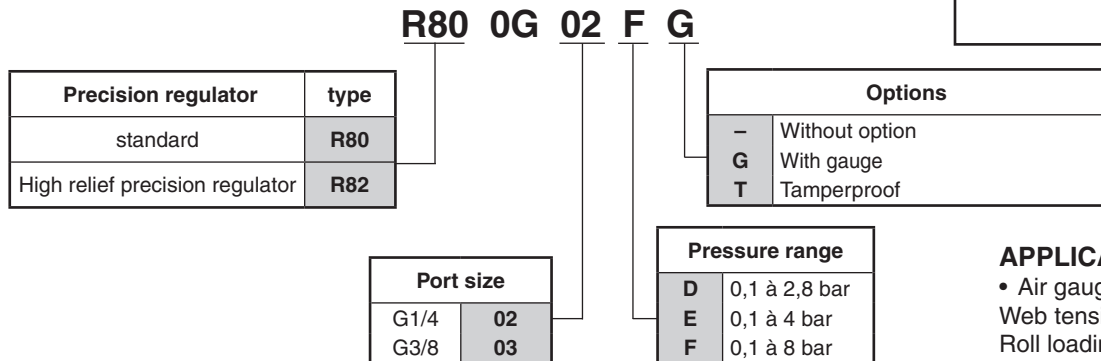

Order exemple: **R800G02F**

This is a R80 Series Precision Regulator with high relief.
Port size is G 1/4. It has a pressure range from 8 bar

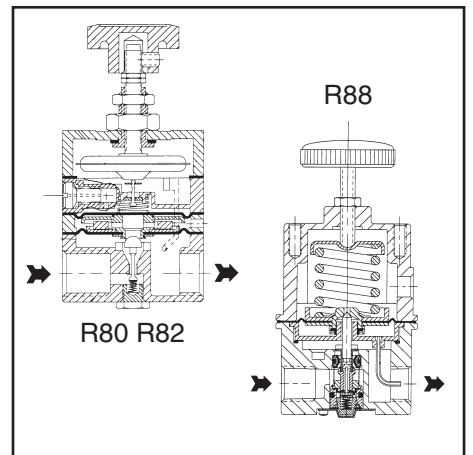

APPLICATIONS

- Air gauging, Gas mixing, Web tensioning, Roll loading, Air hoists

APPLICATIONS

- Test equipment, Roll loading, Web tensioning, Actuators, Gas mixing, Test panels, Clutch and brake controls

ACCESSORIES

Gauge with Center Back Mount

G Option

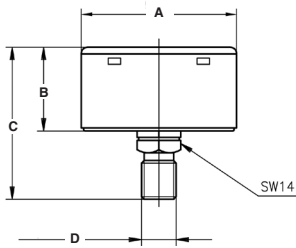

Technical Data and Dimensions (mm)

Type	Option	Code	Pressure Range [psi/bar]	A Ø	B	C	D
standard	G	RB060	0 à 4	50,0	26	44	R 1/4
		RB160	0 à 10	50,0	26	44	R 1/4

Mounting Brackets

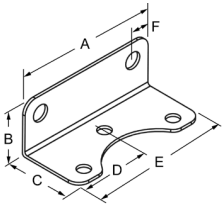

Dimensions [mm]

Code	Series	A	B	C	D	E	F
PK88	R88	76,0	29,0	35,0	38,0	76,0	10,0
PK80	R80 & R82	—	—	—	—	—	—

DIMENSIONS in inch (mm), WEIGHT (g)

Regulators R80 et R82

Tamperproof Model

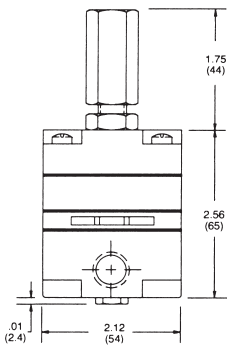

Weight
R80 - R82 : 64 g
R88 : 74 g

Knop Model

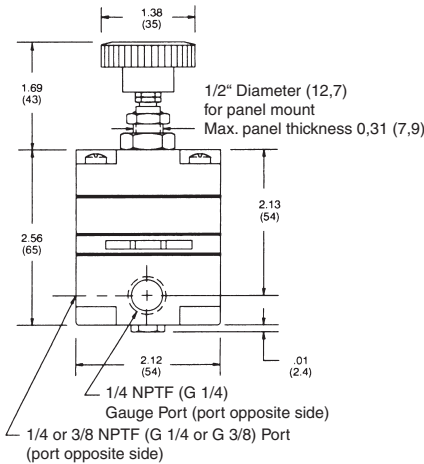

Regulators R88

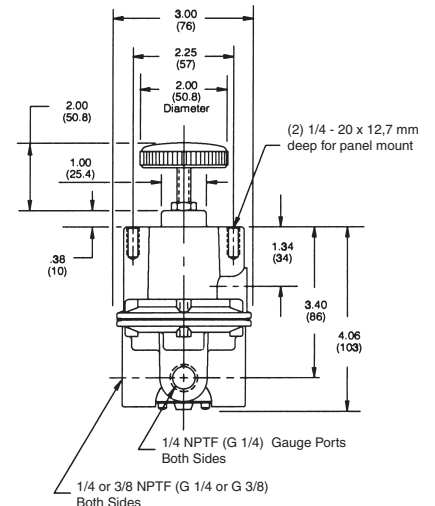

STANDARD HIGH FLOW PRECISION REGULATOR Series R88

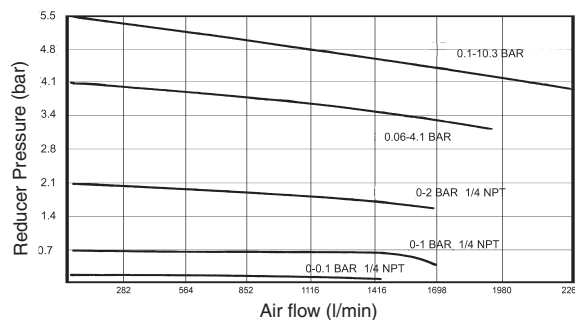

All leaflets are available on: www.asco.com

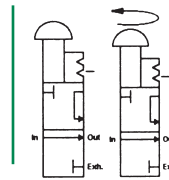

FEATURES

- High Exhausts downstream air when shifted to the closed position
- Colored bright yellow with a red knob
- Can be locked in the closed position with a padlock
- Slo-Start™ feature prolongs life of downstream pneumatic components on VT version
- Detented spool
- Low-friction seals
- Meets OSHA specifications
- Surface mountable

SPECIFICATION

FLUID	: Compressed air or neutral gas, filtered
PORTS	: G 3/8 to G 2
MAX. PRESSURE	: 10 bar
MAX. FLOW	: see table below
OPERATING TEMPERATURE	: 4°C, +50°C



Note: Units should be installed downstream of filtration equipment to avoid damage from backflow.

CHOICE OF EQUIPMENT

type	pipe size		flow		catalogue number	
	in/out	exhaust	in-out	exhaust	VL manual lockout valve	VT manual lockout soft start valve
	G	G	Cv	Cv		
32	3/8	1/2	5,0	5,5	VL32G03Y	VT32G03Y
32	1/2	1/2	6,0	6,0	VL32G04Y	VT32G04Y
32	3/4	1/2	8,3	6,0	VL32G06Y	VT32G06Y
40	3/4	3/4	13,5	11,0	VL40G06Y	VT40G06Y
40	1	1	18,2	14,9	VL40G08Y	VT40G08Y
40	1 1/4	1	19,1	14,9	VL40G10Y	VT40G10Y
40	1 1/2	1	20,3	16,3	VL40G12Y	VT40G12Y
42	3/4	1	11,5	9,0	VL42G06Y	VT42G06Y
42	1	1	12,5	10	VL42G08Y	VT42G08Y
52	1 1/2	1	24	16	VL52G12Y	VT52G12Y
52	2	1	24	16	VL52G16Y	VT52G16Y

ACCESSORIES

Scissor Lockout	
cat. number	Application
VB1	for Manual Lockout Valve



Metal Silencer					
cat. number	Ø	A	B	C	Flow at 6.2 bar CV
M3MB	G 3/8	57,2	50,8	17,5	5,1
M4MB	G 1/2	69,1	61,1	22,2	7,3
M5MB	G 3/4	80,2	71,4	27,0	13,9
M6MB	G 1	98,4	88,1	33,3	19,5

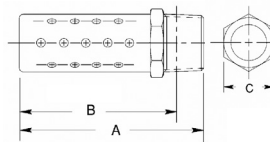

Silencer with Hexagonal Collar					
cat. number	ØA	B	C	D	weight
34600003	G 3/8*	49,2	8,8	24	0,030
34600004	G 1/2*	54,6	11,4	27	0,070
34600005	G 3/4*	82,3	12,7	36	0,300
34600006	G 1*	93,5	14,5	50	0,400

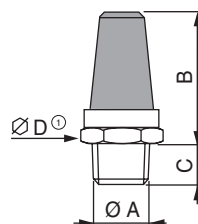

* taper

All leaflets are available on: www.asco.com

VL32 & VT32 Series Valves

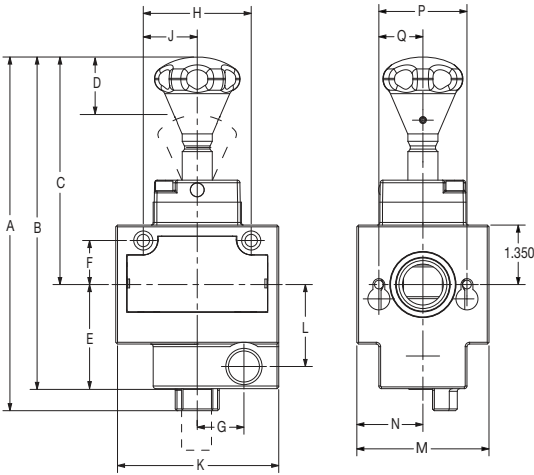

VL52 & VT52 Series Valves

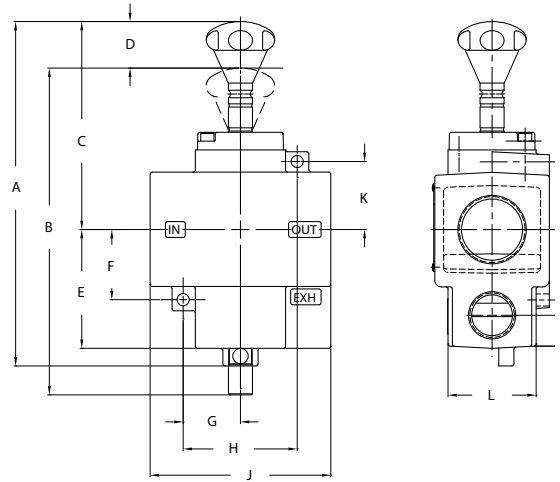

Dimensions [mm], weight [kg]

Series	A	B	C	D	E	F	G	H	J	K	L	M	N	P	Q	weight [kg]
VL32	204,0	191,8	131,3	24,4	59,9	25,4	26,9	62,2	31,1	93,0	47,2	76,2	38,1	50,8	25,4	1,23
VT32	237,2	225,0	164,3	26,7	59,9	25,4	26,9	25,4	31,1	93,0	47,2	76,2	38,1	50,8	25,4	1,39
VL52	248,2	235,5	149,9	33,5	85,9	50,8	41,4	82,6	120,9	38,1	63,5	27,7	79,5	-	-	1,87
VT52	291,3	278,6	192,8	33,5	85,9	50,8	41,4	82,6	120,9	38,1	63,5	27,7	79,5	-	-	2,50

VL & VT40 Series Valves

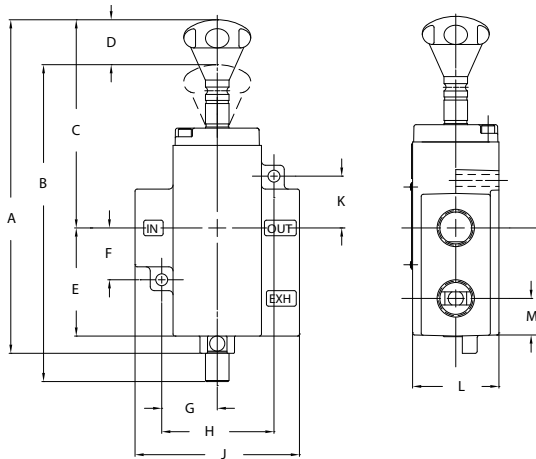

VL & VT42 Series Valves

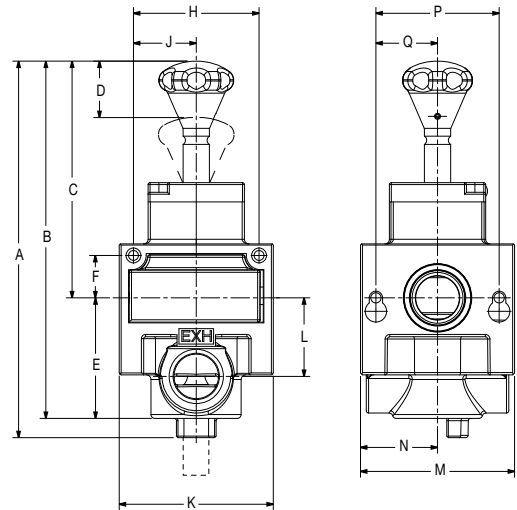

Dimensions [mm], weight [kg]

Series	A	B	C	D	E	F	G	H	J	K	L	M	N	P	Q	weight [kg]
VL40	247,7	235,5	155,4	33,0	79,5	38,1	41,3	82,6	120,9	38,1	63,5	27,7	79,5	-	-	2,00
VT40	290,8	278,6	198,6	33,0	79,5	38,1	41,3	82,6	120,9	38,1	63,5	27,7	79,5	-	-	2,27
VL42	248,4	235,7	131,3	34,0	80,0	28,0	0,0	63,5	41,0	102,0	52,0	102,0	51,0	81,0	41,0	2,25
VT42	291,6	278,9	199,4	34,0	80,0	28,0	0,0	63,5	41,0	102,0	52,0	102,0	51,0	81,0	41,0	2,50



- The Delta™ Series Filters ensure high quality air preparation for high flow rates of up to 2,000 m³/h and more.
- Used for air preparation on air compressors, supply lines and in front of critical applications.
- Wide range of sizes: from 1/4" to 3" ports.
- Different absorbing grades for different applications.

Filter	Filtration	Threads (G)	illustration	series	page
Water Separator		1/4 to 1		F901X	82
Particulate Filter	40 / 25 / 3 µm	1/4 to 3		F901A/I/G	83
Coalescing Filter	1 / 0,3 / 0,01 µm	1/4 to 3		F901H/D/E	84
Adsorbing Grade Filter		1/4 to 3		F901F	85
Accessories					87..90

00620GB-2017/R01
Availability, design and specifications are subject to change without notice. All rights reserved.

All leaflets are available on: www.asco.com

Application Examples for Delta™ Series Filters

Which Delta™ Filter applies to which application?

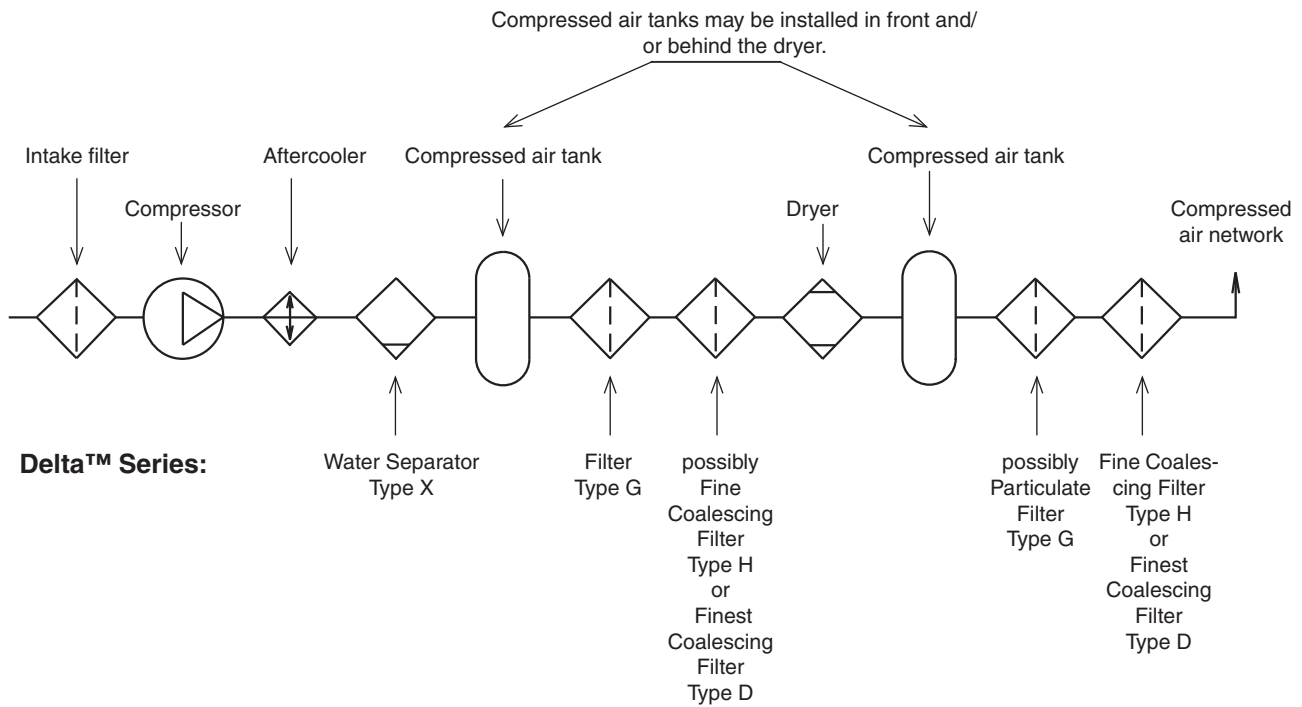

- A Water Separator (type **F901X**) should be installed directly behind the compressor.
- Upstream the dryer at least a 3 µm Particulate Filter (type **F901G**) should be installed. Depending on the dryer principle a Fine Coalescing Filter (1 µm type **F901H**) should be used for refrigerated air dryers and a Finest Coalescing Filter (0.3 µm type **F901D**) for adsorption dryers. Please refer to the operating instructions of the dryer manufacturer.
- Downstream the dryer and compressed air tank a Fine Coalescing Filter (1 µm type **F901H**) should be installed in the main supply line. It might be necessary to install a 3 µm Particulate Filter (type **F901G**) before that.

Compressed Air Quality Classes

Compressed Air Quality Classes (according to ISO 8573-1)

Class	1. Solid Impurities		2. Water Content	3. Oil Content
	max. Part Size [µm]	max. Particle Density [mg/m³]	max. Dew Point [°C]	max. Oil Concentration [mg/m³]
1	0.1	0.1	-70	0.01
2	1	1	-40	0.1
3	5	5	-20	1
4	15	8	+3	5
5	40	10	+7	25

DESCRIPTION e. g.:

Compressed air quality class 3 to ISO 8573-1
or
Compressed air quality class 2.3.2. to ISO 8573-1

TYPICAL APPLICATIONS

Class 4-5: Industrial pneumatics
Class 3: Precision pneumatics / Miniature pneumatics
Class 2: Test equipment (instrument air), upstream adsorption dryers
Class 1: Pure room air applications, food industry, drug industry, cosmetic industry

Which Delta™ Series Filter applies to which air quality class?

Filter Type	Max. Partikel Size [µm]	Approx. max. Oil Content [mg/m³]	Air Quality Class ISO 8573-1
F901A	40	15	5.x.5
F901I	25	15	5.x.5
F901G	3	15	3.x.5
F901H	1	0.5	2.x.3
F901D	0.3	0.1	2.x.2
F901E	0.01	0.01	1.x.1
F901F	Activated carbon	0.003	1*.x.1
On request: sterile filters			*with pre-filter type F901E

Air Quality Class	Filter Recommendation	Air Dryer Principle
1	F901G + F901H + F901E resp. F901H* + F901E or better F901G + F901E + F901F resp. F901E* + F901F	Adsorption dryer -70 °C
2	F901G + F901D resp. F901D* or better F901G + F901H + F901E resp. F901H* + F901E	Adsorption dryer -40 °C
3	F901G + F901H resp. F901H* or better F901G + F901D resp. F901D*	Adsorption dryer -20 °C
4	F901G + F901H resp. F901H*	Refrigerated Dryer +3°C
5	F901A / I / G	Refrigerated Dryer +7 °C
* Should be used with integrated pre-filter (option D)		

All leaflets are available on: www.asco.com

00620GB-2017/R01
Availability, design and specifications are subject to change without notice. All rights reserved.

Delta™ Filter Series • Water Separator

Applications

The water separator is an ideal solution where water contamination is present. Water can damage pneumatic components, degrade your final product, and cause valves and cylinders to stick.

The F901X series utilizes an internal spinner to remove large quantities of contamination by centrifugal action. Water, debris, and rust are spun outward to the inside diameter of the bowl. Gravity then sends the contaminant to the bottom of the bowl for discharge.

The standard execution has got a manual drain.

Order code: (example)

[Configurator - CAD Files](#)

F901	X	G	12		B
Series		Threads	Port Size	Port Size	Options
F901 = Delta™		G = G Threads — = NPTF Threads	02 = 1/4" 04 = 1/2" 06 = 3/4" 08 = 1"	12 = 1 1/2" 16 = 2" 24 = 3"	A = Internal Auto Float Drain (AKF61, 1/4" to 2") B = Mounting Brackets (1/4" to 1" 1/2") W = External Auto Drain (2" and 3")
Type					
X = Water Separator					

Order Example: **F901XG12B**

This is a Delta™ Series Water Separator. Port size is G 1 1/2. It is delivered with a mounted mounting bracket.

Technical Data

Delta™ Filter Series • Water Separator			
Technical Data		Materials of Construction	
Maximum Temperature:	80 °C	Body:	Aluminium
Maximum Pressure:	15 bar (Port size 3": 10 bar)	Seals:	FPM
		Drain:	Brass
		Baffle:	Polyamid, Aluminium

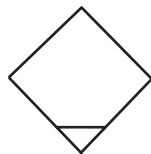

RECOMMENDED USES

- Bulk liquid and solid contamination removal
- Downstream from compressor/aftercoolers
- Protection for coalescing elements from large liquid loading
- Refrigerated compressed air dryers

Flow Rates

based on 7 bar inlet and Δp of 0.1 bar

Series	Port Size	Flow Rate l/min	Flow Rate m³/h
F901XG02	1/4	850	51.0
F901XG04	1/2	2550	153.0
F901XG06	3/4	4672	280.3
F901XG08	1	6088	365.3
F901XG12	1 1/2	9995	599.7
F901XG16	2	19990	1199.4
F900XG24	3	36638	2198.3

Flow Rate Correction Table for other operating pressures

Operating Pressure [bar]	1	3	5	7	9	11	13	15
Correction Factor	0.38	0.65	0.84	1	1.15	1.25	1.36	1.46

All leaflets are available on: www.asco.com

Delta™ Filter Series • 40 / 25 / 3 µm Particulate Filter

Applications

The particulate filter is designed for heavy dirt loading. Large particles such as rust, desiccant dust, and debris will rob the life of your pneumatic components. Contaminant is generated from desiccant type air dryers, older carbon steel pipes, and from the intake of a compressor.

The F901A / I / G features a pleated design - folds of cellulose composite media which provide a large amount of surface area and extend the life of the element. When air flows - from the outside of the element to the inside - the particles are trapped in the space between the filter bowl and the element.

The standard execution has got a manual drain. Oil contents remaining after the Particulate Filter: up to approx. 15 mg/m³.

Order code: (example)

[Configurator - CAD Files](#)

F901	G	G	04		A
Series	Threads		Port Size		Options
F901 = Delta™	G = G Threads — = NPTF Threads		02 = 1/4"	10 = 1 1/4"	A = Internal Auto Float Drain (AKF61, 1/4" - 3")
Typ			03 = 3/8"	12 = 1 1/2"	B = Mounting Brackets (1/4" to 1" 1/2)
A = 40 µm Filter Element			04 = 1/2"	16 = 2"	G = Differential Pressure Gauge
I = 25 µm Filter Element			06 = 3/4"	20 = 2 1/2"	W = External Auto Drain (2" and 3")
G = 3 µm Filter Element			08 = 1"	24 = 3"	

Order Example: **F901GG04**

This is a Delta™ Series 3 µm Particulate Filter. Port size is G 1/2. It is equipped with a manual drain (standard).

Technical Data

Delta™ Filter Series • 40 / 25 / 3 µm Particulate Filter							
Option	No Option	Option A	Option A	Option G	Option AG	Option AG	Option F
Port Size	1/4 - 3	1/4 - 1	1 1/4 - 3	1/4 - 3	1/4 - 1	1 1/4 - 3	1/4 - 3
Maximum Temperature:	135 °C	65 °C	120 °C	80 °C	65 °C	80 °C	50 °C
* Maximum Pressure:	*15 bar	10 bar	10 bar	*15 bar	10 bar	10 bar	10 bar

* Maximum Pressure Port Sizes 2 1/2 and 3" : 10 bar

Materials of Construction

Body:	Aluminium	Tie Rod:	Brass
Seals:	FPM	End Caps:	Anodized Aluminium
Drain:	Brass		



Option G

Flow Rates

based on 7 bar inlet and Δp of 0,1 bar

Series	Port Size	Flow Rate NI/min	Flow Rate m³/h
F901GG02	1/4	1048	62.9
F901GG03	3/8	2265	135.9
F901GG04	1/2	2973	178.4
F901GG06	3/4	5097	305.8
F901GG08	1	7079	424.7
F901GG10	1 1/4	14015	841.0
F901GG12	1 1/2	16819	1009.1
F901GG16	2	32703	1962.2
F901GG20	2 1/2	42046	2522.9
F901GG24	3	52550	3153.0

Flow values for 40 and 25 µm filter element on request

RECOMMENDED USES

- Solid bulk contamination removal
- Afterfilter to a desiccant dryer
- Protection for coalescing in heavy aerosol applications
- 40 resp. 25 or 3 µm particle removal in "Dry" systems

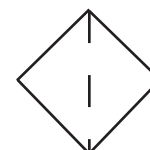

Flow Rate Correction Table
for other operating pressures

Operating Pressure [bar]	1	3	5	7	9	11	13	15
Correction Factor	0.38	0.65	0.84	1	1.15	1.25	1.36	1.46

All leaflets are available on: www.asco.com

00620GB-2017/R01 Availability, design and specifications are subject to change without notice. All rights reserved.

Applications

The 1 µm Coalescing Filter is utilized when low pressure drop or crude separation is required. The filter element is preferred in low pressure and vacuum application so that the efficiency of the compressor or pump is not sacrificed. Also, the coalescing element will take out crude amounts of large liquid oil and water particles, specially downstream of a compressor to protect a dryer. This filter removes over 99,9% of particles.

The 0,3 µm Coalescing Filter is utilized when clean air is required and longer component life is desired. It is recommended in most point-of-use applications for industrial use. Also, the Finest Coalescing Filter removes small particles of oil, water, and rust that can create problems in painting and coating processes.

The 0,01 µm Coalescing Filter is ideal where critically clean air is needed and pressure drop is not a concern. It is a polisher filter to clean up any remains of particles or oil that are left over from the compressor room filtration. It is mainly a point-of-use filter that is targeted specifically for critical processes. It is also used to protect and extend the life of membrane filters.

The F901H/D/E features a unique vacuum-formed process. It utilizes micro-glass fibers in raw form to create a seamless, depth-loading media. Combined with a rigid fiber-coating epoxy, the filter element has great strength, high efficiency, and superior life.

The standard execution has got a manual drain. Oil contents remaining after the Fine Coalescing Filter: up to approx. 0,5 mg/m³.

Order code: example

[Configurator - CAD Files](#)

F901	H	G	04	AG
Series		Threads	Port Size	Port Size
F901 = Delta™		G = G Threads	02 = 1/4"	10 = 1 1/4"
			03 = 3/8"	12 = 1 1/2"
			04 = 1/2"	16 = 2"
			06 = 3/4"	20 = 2 1/2"
			08 = 1"	24 = 3"
Type				Options
H = 1 µm Filter Element				A = Internal Auto Float Drain (AKF61, 1/4" - 3")
D = 0,3 µm Filter Element				B = Mounting Brackets (1/4" to 1 1/2")
E = 0,01 µm Filter Element				D = Internal Pleated 3 µm Prefilter
				G = Differential Pressure Gauge

Order Example: F901HG04AG
This is a Delta™ Series 1 µm Fine Coalescing Filter. Port size is G 1/2. It is equipped with an automatic drain and a mounted differential pressure gauge.

Technical Data

Delta™ Filter Series • Coalescing Filter						
Option	No Option	Option A	Option A	Option G	Option AG	Option AG
Port Size	1/4 - 3	1/4 - 1	1 1/4 - 3	1/4 - 3	1/4 - 1	1 1/4 - 3
Maximum Temperature:	135 °C	65 °C	120 °C	80 °C	65 °C	80 °C
* Maximum Pressure:	*15 bar	10 bar	10 bar	*15 bar	10 bar	10 bar

* Maximum Pressure Port Sizes 2 1/2" and 3" : 10 bar



Option G



RECOMMENDED USES

- Mainline plant filtration
- Prefilter to refrigerated air dryer
- Heavy oil concentration removal
- 1 µm particle removal in "Dry" systems

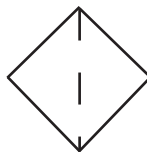

Flow Rate Correction Table for other operating pressures

Operating Pressure [bar]	1	3	5	7	9	11	13	15
Correction Factor	0,38	0,65	0,84	1	1,15	1,25	1,36	1,46

Materials of Construction

Body:	Aluminium	Tie Rod:	Brass
Seals:	FPM	End Caps:	Anodized Aluminium
Drain:	Brass		

Flow Rates based on 7 bar inlet and Δp of 0.1 bar

Series	Port Size	Flow rate					
		H (1 µm)		D (0.3 µm)		E (0.01 µm)	
		l/min	m³/h	l/min	m³/h	l/min	m³/h
F901.G02	1/4	925	55	865	50	620	35
F901.G03	3/8	1855	110	1790	105	1080	65
F901.G04	1/2	2160	130	2005	120	1235	75
F901.G06	3/4	5405	325	4015	240	2470	150
F901.G08	1	7725	465	5405	325	3245	195
F901.G10	1 1/4	14830	890	9265	555	5560	335
F901.G12	1 1/2	17795	1070	11120	665	6675	400
F901.G16	2	34600	2075	21625	1295	12975	780
F901.G20	2 1/2	44480	2670	27800	1670	16680	1000
F901.G24	3	55605	3335	34750	2085	20850	1250

All leaflets are available on: www.asco.com

Applications

The Adsorbing Grade Filter removes oil and larger hydrocarbon vapor from the compressed air stream. Since it only removes vapor, a coalescing filter - specifically the F901D - should be used immediately upstream of the adsorbing filter. Since optimum adsorption occurs at lower temperatures, it is recommended to apply the filter as close to the point-of-use as possible.

The F901F features fine activated charcoal impregnated on polyester. The activated carbon particles have a high affinity to vapor and are extremely efficient due to the tremendous amount of surface area present. The adsorbing element and the coalescing element should be changed every 3 to 6 months depending on the application.

The standard execution has got a manual drain. Oil contents remaining after the Adsorbing Grade Filter: up to approx. 0,003 mg/m³.

Order code:

[Configurator - CAD Files](#)

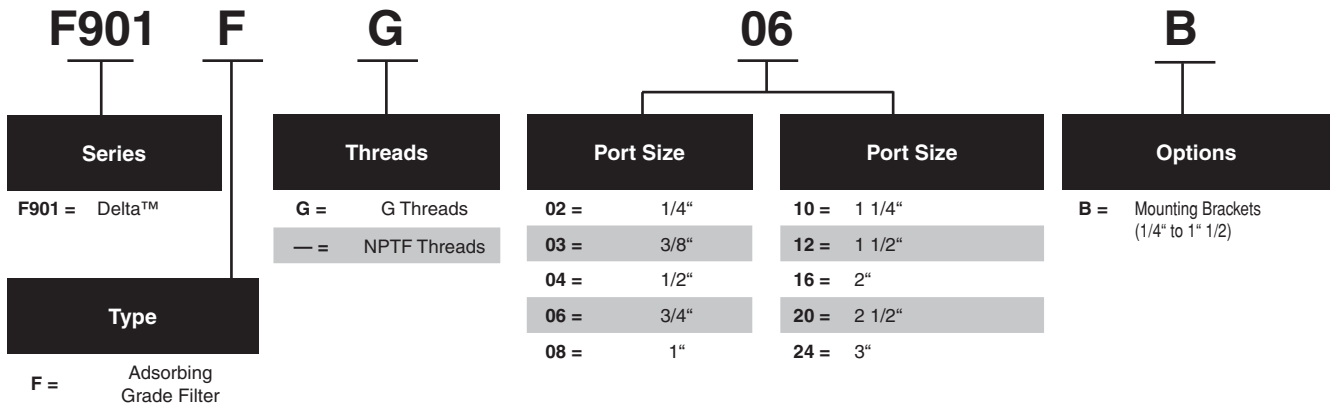

Order Example: **F901FG06B**

This is a Delta™ Series Adsorbing Grade Filter. Port size is G 3/4. It is equipped with a manual drain (standard) and is delivered with a mounted mounting bracket.

Technical Data

Delta™ Filter Series • Adsorbing Grade Filter			
Technical Data		Materials of Construction	
Maximum Temperature:	65 °C	Body:	Aluminium
Maximum Pressure:	15 bar (Port sizes 2 1/2 and 3": 10 bar)	Seals:	FPM
		Drain:	Brass
		Tie Rod:	Brass
		End Caps:	Anodized Aluminium

Flow Rates

based on 7 bar inlet and Δp of 0.1 bar

Series	Port Size	Flow Rate NI/min	Flow Rate m ³ /h
F901FG02	1/4	850	51.0
F901FG03	3/8	2124	127.2
F901FG04	1/2	2548	153.0
F901FG06	3/4	5663	339.6
F901FG08	1	7079	424.8
F901FG10	1 1/4	8494	510.0
F901FG12	1 1/2	10193	611.4
F901FG16	2	19820	1189.2
F901FG20	2 1/2	25483	1528.8
F901FG24	3	31853	1911.0

RECOMMENDED USES

- Breathing air applications
- Food and drug industries having direct product contact with exhaust air
- Odor-free air applications
- Heavier hydrocarbon vapor removal

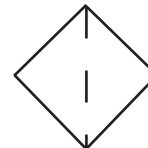

Flow Rate Correction Table for other operating pressures

Operating Pressure [bar]	1	3	5	7	9	11	13	15
Correction Factor	0.38	0.65	0.84	1	1.15	1.25	1.36	1.46

All leaflets are available on: www.asco.com

00620GB-2017/R01 Availability, design and specifications are subject to change without notice. All rights reserved.

Delta™ Filter Series • Filter Assemblies

Applications

Many applications require air quality that cannot be attained with one filter housing. The chart below shows typical applications and their recommended filter element combinations. Using this chart, determine the port size and flow for your application.



Flow Rates for Assemblies

NI/s by port size based on 7 bar inlet

Assemblies	Filter Element	Port Size										
		1/4	3/8	1/2	3/4	1	1X	1 1/4	1 1/2	2	2 1/2	3
Between aftercooler and dryer	X H	8.5	—	27.0	55.0	83.0	—	—	167.0	333.0	—	611.0
Blow molding	G D F	31.0	31.0	31.0	47.0	57.0	76.0	142.0	170.0	330.0	451.0	531.0
Breathing air	G D F	31.0	31.0	31.0	47.0	57.0	76.0	142.0	170.0	330.0	451.0	531.0
Compressing air measuring instruments	G D	31.0	31.0	31.0	47.0	57.0	76.0	142.0	170.0	330.0	451.0	531.0
Compressing air motors	G D	31.0	31.0	31.0	47.0	57.0	76.0	142.0	170.0	330.0	451.0	531.0
Electronics	G H E	18.0	18.0	18.0	28.0	34.0	45.0	85.0	102.0	198.0	225.0	319.0
Film laboratories	G D F	31.0	31.0	31.0	47.0	57.0	76.0	142.0	170.0	330.0	451.0	531.0
Foot packaging	G D F	31.0	31.0	31.0	47.0	57.0	76.0	142.0	170.0	330.0	451.0	531.0
Hospital services	G D F	31.0	31.0	31.0	47.0	57.0	76.0	142.0	170.0	330.0	451.0	531.0
Paint spraying systems	G D	31.0	31.0	31.0	47.0	57.0	76.0	142.0	170.0	330.0	451.0	531.0
Paint spraying systems (critical)	G D F	31.0	31.0	31.0	47.0	57.0	76.0	142.0	170.0	330.0	451.0	531.0
Pharmaceutical industry	G D F	31.0	31.0	31.0	47.0	57.0	76.0	142.0	170.0	330.0	451.0	531.0
Pneumatic control systems	G D	31.0	31.0	31.0	47.0	57.0	76.0	142.0	170.0	330.0	451.0	531.0
Pneumatic conveying systems	G D	31.0	31.0	31.0	47.0	57.0	76.0	142.0	170.0	330.0	451.0	531.0
Pneumatic tools	G D	31.0	31.0	31.0	47.0	57.0	76.0	142.0	170.0	330.0	451.0	531.0
Precision analyzers	G H F	18.0	18.0	18.0	28.0	34.0	45.0	85.0	102.0	198.0	255.0	319.0
Process air	H D F	31.0	31.0	31.0	47.0	57.0	76.0	142.0	170.0	330.0	451.0	531.0

FILTER ELEMENTS GRADES

- X = Water Separator
- G = 40 / 25 / 3 µm Filter
- H = 1.0 µm Fine Coalescing Filter

- D = 0.3 µm Finest Coalescing Filter
- E = 0.01 µm Ultra Fine Coalescing Filter
- F = Adsorbing Grade Filter

All leaflets are available on: www.asco.com

Delta™ Filter Series • Dimensions

Dimensions: All Filter Types and Port Sizes

Dimensions [mm]

Series	A	B	C	D	E**
F901*G02	95.0	46.0	20.0	238.0	115.0
F901*G03	95.0	46.0	20.0	238.0	115.0
F901*G04	95.0	46.0	20.0	238.0	115.0
F901*G06	116.0	46.0	34.0	373.0	215.0
F901*G08	116.0	46.0	34.0	373.0	215.0
F901*G10	116.0	46.0	34.0	535.0	375.0
F901*G12	116.0	46.0	34.0	535.0	375.0
F901*G16	160.0	46.0	43.0	681.0	500.0
F901*G20	280.0	46.0	73.0	766.0	500.0
F901*G24	280.0	46.0	73.0	766.0	500.0

* Option for Type

** The "E" dimension refers to the amount of space needed below the bottom of the bowl in order to remove the bowl

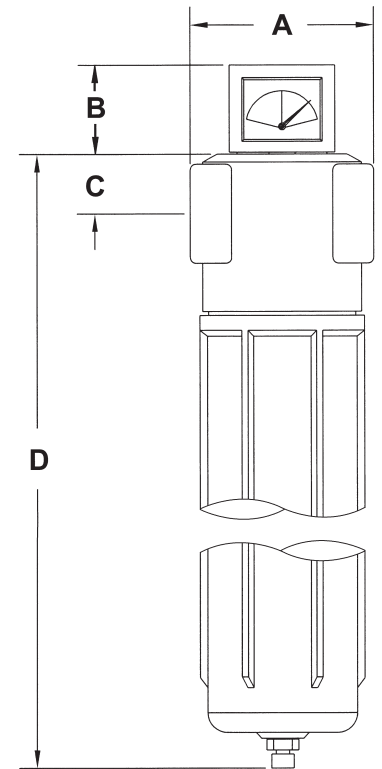

Water Separator, all Sizes

Dimensions [mm]

Series	A	B	C	D	E*
F901XG02	95.0	—	20.0	238.0	75.0
F901XG04	95.0	—	20.0	238.0	75.0
F901XG06	116.0	—	34.0	273.0	100.0
F901XG08	116.0	—	34.0	273.0	100.0
F901*G12	116.0	—	34.0	273.0	100.0
F901*G16	160.0	—	43.0	332.0	100.0
F901*G24	280.0	—	73.0	439.0	115.0

* The "E" dimension refers to the amount of space needed below the bottom of the bowl in order to remove the bowl

Delta™ Filter Series • Accessories

Mounting Brackets

Mounting brackets are used to fix Delta Series™ filters to a panel. The brackets, made of sturdy stainless steel, are screwed into the bracket mounting holes located on the in and out ports.

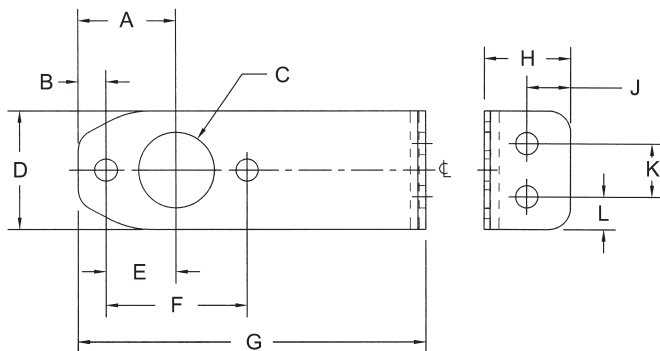

Dimensions [mm]

Order Code (1 pair)	Port Size	A	B	C Ø	D	E	F	G	H	J	K	L
BRK9001	1/4 - 1/2	29.0	8.0	22.0	35.0	21.0	41.0	102.0	25.0	13.0	16.0	10.0
BRK9002	3/4 - 1 1/2	38.0	7.0	42.0	64.0	31.0	63.0	127.0	25.0	10.0	38.0	13.0

Note: No mounting brackets available for port sizes G 2 - G 3

00620GB-2017/R01 Availability, design and specifications are subject to change without notice. All rights reserved.

All leaflets are available on: www.asco.com

Delta™ Filter Series • Accessories

Double Nipple for Filter Mounting

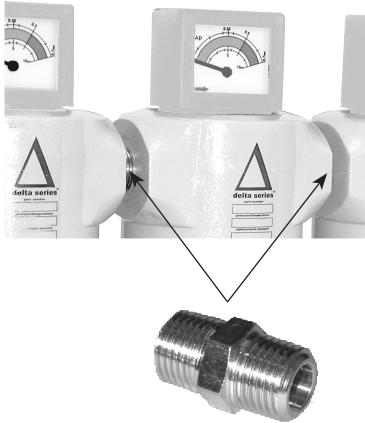

Double Nipple

Order Code	Port Size	Application
N441-001-001	1/4	for Filter mounting 40 / 25 / 3 µm Particulate Filter; 1 µm Fine Coalescing Filter; 0.3 µm Finest Coalescing Filter; 0.01 µm Ultra Fine Coalescing Filter and Adsorbing Grade Filter
N441-002-002	3/8	
N441-003-003	1/2	
N441-006-006	3/4	
N441-007-007	1	
N441-008-008	1 1/4	
N441-009-009	1 1/2	
N441-010-010	2	
N441-011-011	2 1/2	
N441-012-012	3	

Automatic Drain

Automatic Drain

The Auto Drain is installed into the bottom of the filter bowl. As the liquid level inside the bowl increases, the tire-like float lifts, allowing the liquid to drain.



AKF61

Technical Data and Dimensions [mm]

Order Code	Description	Option	Size	Max. Temperature	Max. Pressure	A	B	C
AKF61	for filters with port size 1/4 to 3"	A	3/8	—	10 bar	—	—	—

Manual Drain

Manual Drain

All Delta™ Series Filters are equipped with manual drain MD90 as standard.



Order Code	Size	Application
MD90	3/8	for Water Separator; 40 / 25 / 3 µm Particulate Filter; 1 µm Coarse Coalescing Filter; 0.3 µm Fine Coalescing Filter; 0.01 µm Ultra Fine Coalescing Filter and Adsorbing Grade Filter, for all size

Delta™ Filter Series • Accessories

Spare Bowl

Spare Bowl for Filter

Order Code	Port Size	Application
BKF9001-B	1/4, 3/8 and 1/2	for 40 / 25 / 3 µm Particulate Filter; 1 µm Fine Coalescing Filter; 0.3 µm Finest Coalescing Filter; 0.01 µm Ultra Fine Coalescing Filter and Adsorbing Grade Filter
BKF 9002-B	3/4 and 1	
BKF9004-B	1 1/4 and 1 1/2	
BKF9005-B	2	
BKF9006	2 1/2 and 3	
Note: Thread sizes of lower bowl are (for drain) G 3/8		



Spare Bowl for Filter or Water Separator

Spare Bowl for Water Separator

Order Code	Port Size	Application
BKF9001-B	1/4 and 1/2	for Water Separator
BKF 9004S-B	3/4; 1; 1 1/2 and 2	
BKF9005S-B	2	
BKF9006S	3	
Note: Thread sizes of lower bowl are (for drain) G 3/8		

Filter Element

Filter Element with 3 µm Prefilter

Replacement Filter Elements

Replacement Filter Elements

Order Code	Port Size	Porosity
Element		
EKF9004A-B	1/4, 3/8 and 1/2	40 µm
EKF9004I-B	1/4, 3/8 and 1/2	25 µm
EKF9004G-B	1/4, 3/8 and 1/2	3 µm
EKF9004H-B	1/4, 3/8 and 1/2	1 µm
EKF9004HD-B with 3 µm Prefilter	1/4, 3/8 and 1/2	1 µm
EKF9004D-B	1/4, 3/8 and 1/2	0.3 µm
EKF9004DD-B with 3 µm Prefilter	1/4, 3/8 and 1/2	0.3 µm
EKF9004E-B	1/4, 3/8 and 1/2	0.01 µm
EKF9004ED-B with 3 µm Prefilter	1/4, 3/8 and 1/2	0.01 µm
EKF9004F-B	1/4, 3/8 and 1/2	Adsorber
EKF9008A-B	3/4 and 1	40 µm
EKF9008I-B	3/4 and 1	25 µm
EKF9008G-B	3/4 and 1	3 µm
EKF9008H-B	3/4 and 1	1 µm
EKF9008HD-B with 3 µm Prefilter	3/4 and 1	1 µm
EKF9008D-B	3/4 and 1	0.3 µm
EKF9008DD-B with 3 µm Prefilter	3/4 and 1	0.3 µm
EKF9008E-B	3/4 and 1	0.01 µm
EKF9008ED-B with 3 µm Prefilter	3/4 and 1	0.01 µm
EKF9008F-B	3/4 and 1	Adsorber

Replacement Filter Elements

Order Code	Port Size	Porosity
Element		
EKF9012A-B	1 1/4 and 1 1/2	40 µm
EKF9012I-B	1 1/4 and 1 1/2	25 µm
EKF9012G-B	1 1/4 and 1 1/2	3 µm
EKF9012H-B	1 1/4 and 1 1/2	1 µm
EKF9012HD-B with 3 µm Prefilter	1 1/4 and 1 1/2	1 µm
EKF9012D-B	1 1/4 and 1 1/2	0.3 µm
EKF9012DD-B with 3 µm Prefilter	1 1/4 and 1 1/2	0.3 µm
EKF9012E-B	1 1/4 and 1 1/2	0.01 µm
EKF9012ED-B with 3 µm Prefilter	1 1/4 and 1 1/2	0.01 µm
EKF9012F-B	1 1/4 and 1 1/2	Adsorber
EKF9016A-B	2	40 µm
EKF9016I-B	2	25 µm
EKF9016G-B	2	3 µm
EKF9016H-B	2	1 µm
EKF9016HD-B with 3 µm Prefilter	2	1 µm
EKF9016D-B	2	0.3 µm
EKF9016DD-B with 3 µm Prefilter	2	0.3 µm
EKF9016E-B	2	0.01 µm
EKF9016ED-B with 3 µm Prefilter	2	0.01 µm
EKF9016F-B	2	Adsorber
EKF9024A	2 1/2 and 3	40 µm
EKF9024I	2 1/2 and 3	25 µm
EKF9024G	2 1/2 and 3	3 µm
EKF9024H	2 1/2 and 3	1 µm
EKF9024HD with 3 µm Prefilter	2 1/2 and 3	1 µm
EKF9024D	2 1/2 and 3	0.3 µm
EKF9024DD with 3 µm Prefilter	2 1/2 and 3	0.3 µm
EKF9024E	2 1/2 and 3	0.01 µm
EKF9024ED with 3 µm Prefilter	2 1/2 and 3	0.01 µm
EKF9024F	2 1/2 and 3	Adsorber

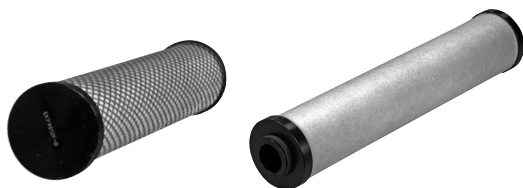

00620GB-2017/R01 Availability, design and specifications are subject to change without notice. All rights reserved.

All leaflets are available on: www.asco.com

Delta™ Filter Series • Accessories

Housing Seal

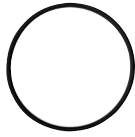

Housing Seal

Order Code	Port Size	Application
FPHS9001-04	1/4; 3/8 and 1/2	for Water Separator;
FPHS9001-12	3/4; 1; 1 high flow; 1 1/4; and 2	40 / 25 / 3 µm Particulate Filter;
FPHS9001-16	2	1 µm Coarse Coalescing Filter;
FPHS9001-24	2 1/2 and 3	0.3 µm Fine Coalescing Filter;
		0.01 µm Ultra Fine Coalescing Filter and Adsorbing Grade Filter

Pressure Indicators

Pressure Indicators

allow the exact determination of pressure drop between supply and output pressure, caused by the filter element. The air resistance within the filter rises proportionally with the pollution of the filter element and that causes the pressure drop.

Attention: The mechanical instrument PDI92 only react to a specific value of pressure drop. That can cause unnecessary short intervals of exchanging at a high supply pressure or dangerously long intervals at a low supply pressure. Additionally, the mechanical instruments are only useful if compressed air is in use, because just then a pressure drop is measured. Excesses of the limit value are not permanently shown and not processed to a place further away, an instrument panel for example.

The dial indicator **PDI92** with its metall housing has a pointer and a scale. If the pointer indicates into the red section of the scale starting at 0.35 bar, the filter has to be interchanged.

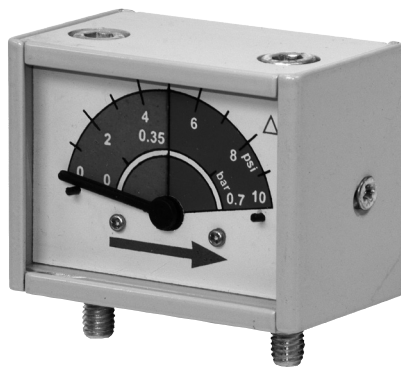

PDI92

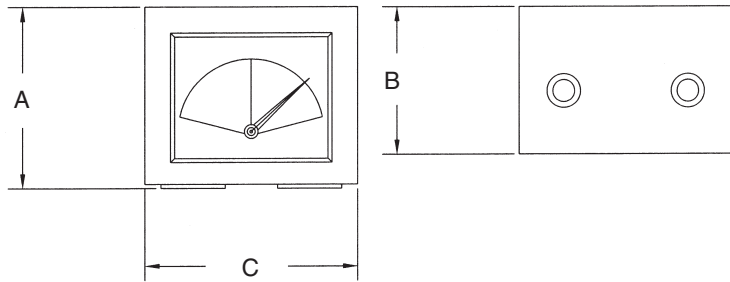

Differential Pressure Gauge
for Filter with Port Size 1/4 - 3

Dimensions [mm]

Order Code	Port Size	A	B	C
PDI92	1/4 - 3	46,0	62,0	37,0