

ASCO™ Zero Minimum Solenoid Valves

Air Piloted, Spring Return, Shutdown System | Brass or Stainless Steel Bodies Air and Inert Gas | 1/4" - 1/2" NPT

**SERIES
316**

- Brass body construction for general atmospheres; stainless steel for corrosive atmospheres
- Can be internally piloted, or externally piloted to convert valve to zero minimum operation by flipping a gasket
- When externally piloted, loss of electrical power or auxiliary air exhausts air from the actuator and shifts process valve to its original position
- When internally piloted, loss of electric power returns the valve to its original position
- Also available with Low Power or Intrinsically Safe solenoids. See Special Service Valve Section

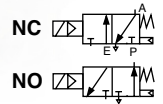
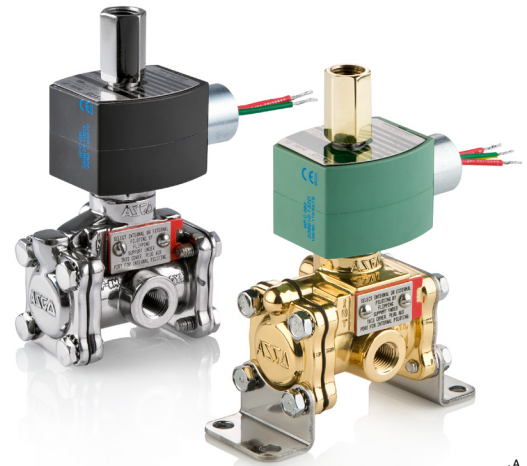

Construction

Valve Parts in Contact with Fluids		
Body	Brass	316 Stainless Steel
End Plate	304 Stainless Steel	316 Stainless Steel
Seals and Discs	Low Temp NBR	
Core Tube	305 Stainless Steel	
Core Guide	CA	
Shading Coil	Copper	Silver

Electrical

Standard Coil and Class of Insulation	Watt Rating and Power Consumption				Spare Coil Part Number					
	DC Watts	AC			General Purpose		Explosionproof (EF)		Explosionproof (EV)	
		Watts	VA Holding	VA Inrush	AC	DC	AC	DC	AC	DC
F	11.6	10.1	25	50	238610	238710	272614	238714	274614	274714

Standard Voltages: 24, 120, 240, 480 volts AC, 60 Hz (or 110, 220 volts, AC, 50 Hz).
6, 12, 24, 120, 240 volts DC. Must be specified when ordering.
Other voltages are available when required.

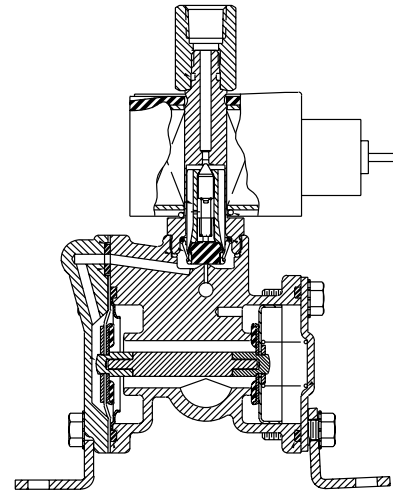

Solenoid Enclosures

Brass Body Valves:

Standard: Watertight, Types 1, 2, 3, 3S, 4, and 4X.

Optional: Explosionproof and Watertight, Types 3, 3S, 4, 4X, 6, 6P, 7, and 9. (Add prefix "EF" to catalog number.)

Stainless Steel Valves:

Standard: Explosionproof and Watertight, Types 3, 3S, 4, 4X, 6, 6P, 7, and 9.

See Optional Features Section for other available options.

Installation

All valves may be mounted in any position.

316 Stainless Steel mounting brackets available from ASCO. Add suffix "MB".

Nominal Ambient Temp. Ranges

Standard Construction:

AC: -4°F to 125°F (-20°C to 52°C)

DC: -4°F to 104°F (-20°C to 40°C)

Approvals

Valves with prefix "EF" or "EV"; UL approved and CSA certified solenoid. Meets applicable CE directives.

SIL 3 capable per IEC 61508 on normally closed const. Third party certification provided by EXIDA.

ATEX/IECEx certified with prefix "EV" as listed.

Refer to Optional Features Electrical Section for details.

Specifications (English units)

Pipe Size in	Orifice Size in (mm)	Flow Factor Cv (Kv)	Min.	Max. Air Pressure psi (bar)		Catalog Number		Const. Ref.	Max. Fluid Temp. °F (°C)		Watt Rating/ Class of Coil Insulation	
				AC	DC	Brass Body	Stainless Steel		AC	DC	AC	DC
NORMALLY CLOSED (Closed when de-energized) ① – PFD_{AVG} = 9.30 x 10⁻⁴												
1/4	5/16 (8)	1.5 (1.3)	②	150 (10)	120 (8)	8316G001	EV8316G081 ③	1	180 (82)	120 (49)	10.1/F	11.6/F
3/8	5/16 (8)	1.5 (1.3)	②	150 (10)	120 (8)	8316G002	EV8316G082 ③	1	180 (82)	120 (49)	10.1/F	11.6/F
3/8	5/8 (16)	4 (3.4)	②	150 (10)	120 (8)	8316G003	-	2	180 (82)	120 (49)	10.1/F	11.6/F
1/2	5/8 (16)	4 (3.4)	②	150 (10)	120 (8)	8316G004 ③	EV8316G084 ③	2	180 (82)	120 (49)	10.1/F	11.6/F

① Consult factory for Normally Open. ② Zero minimum when valve selection gasket is in external position and proper auxiliary air pressure is applied. ③ ATEX/IECEx certified with prefix "EV". See graph below for pilot line pressure vs. mainline pressure. Minimum 15 psi (1 bar) operating pressure differential when selection gasket is in the internal position.

IMPORTANT: Internal mode Minimum Operating Pressure Differential must be maintained between the pressure and exhaust ports. Supply and exhaust piping must be full area and unrestricted. ASCO flow controls and similar components must be installed in the cylinder lines only.

Dimensions: inches (mm)

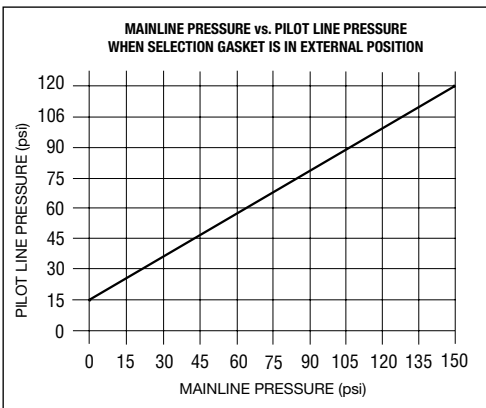

Const. Ref. 1

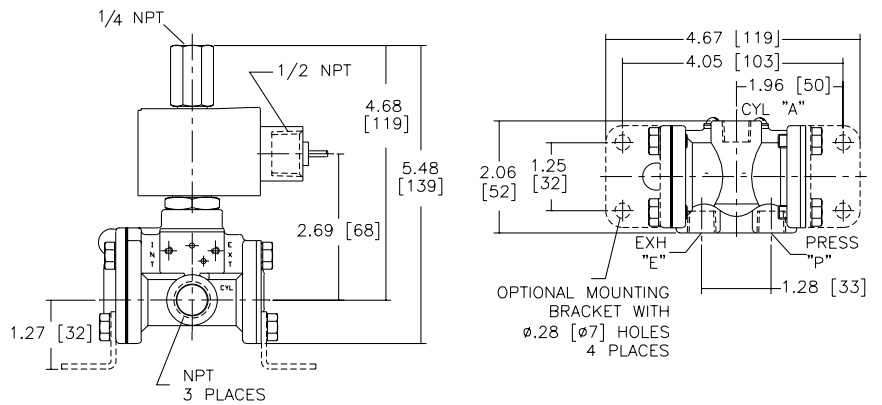

INTERNAL PILOTING MODE FLOW DIAGRAMS

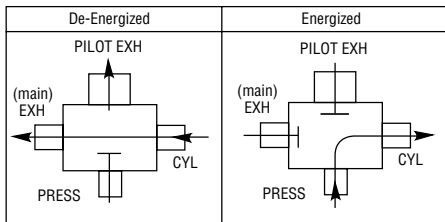

EXTERNAL PILOTING MODE FLOW DIAGRAMS

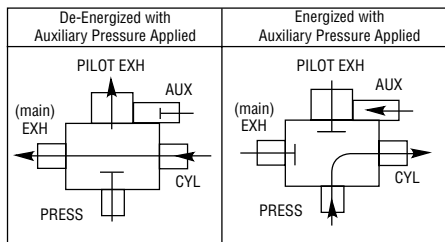

Const. Ref. 2

